



Telecab17

Home Lift

Planning Guide

 savaria.

Applicable Codes:

ASME A17.1/CSA-B44

Safety Code for Elevators and Escalators

Section 5.3 – Private Residential Elevators

Copyright © 2022
Savaria Concord Lifts, Inc.
All rights reserved.

Printed in Canada

Purpose of This Guide

This guide assists architects, contractors, and lift professionals to incorporate the Telecab17 Home Lift into a residential building design. The design and manufacture of the Telecab17 Home Lift meets the requirements of the following codes and standards:

- ASME A17.1 1996, Section 5.3
- ASME A17.1/CSA B44 2000, Section 5.3
- ASME A17.1/CSA B44 2004, Section 5.3
- ASME A17.1 2004, Addendum 2005, Section 5.3
- ASME A17.1/CSA B44 2007, Section 5.3
- ASME A17.1/CSA B44, Addendum 2008, Section 5.3
- ASME A17.1/CSA B44 2010, Section 5.3
- ASME A17.1/CSA B44 2013, Section 5.3
- ASME A17.1/CSA B44 2016, Section 5.3
- ASME A17.1/CSA B44 2019, Section 5.3

We recommend that you contact your local authority having jurisdiction to ensure that you adhere to all local rules and regulations pertaining to Home Lifts.

IMPORTANT: This Planning Guide provides nominal dimensions and specifications useful for the initial planning of a Home Lift project. Dimensions and specifications are subject to change without notice due to continually evolving code and product applications.

Before beginning actual construction, please consult Savaria Corporation or the authorized Savaria dealer in your area to ensure you receive your site-specific installation drawings with the dimensions and specifications for your project.

Visit our website for the most recent Telecab17 drawings and dimensions.

NOTE: These specifications are for Telecab17 only. For other sizes with a smaller load capacity, ask your Savaria dealer about the original Telecab (500-lb capacity) described in the original Telecab Planning Guide, P/N 000698.

How to Use This Guide

- 1 Determine your client's intended use of the lift.
- 2 Determine the local code requirements.
- 3 Determine the site installation parameters.
- 4 Determine the cab type and hoistway size requirements.
- 5 Plan for electrical requirements.

History

March 2, 2017 – Initial release



March 15, 2017 – Added Note on this page, at top of page 4, and on page 7 referencing the original Telecab product

June 26, 2017 – Revised drawings on pages 8 and 9

November 21, 2017 – Revised codes above

December 20, 2017 – Revised R2 value in drawing on page 9

March 22, 2018 – Revised power supply spec on page 4 from 30A to 20A

July 26, 2018 – Revised power supply spec on page 4

December 20, 2019 – Revised optional equipment line in spec table on page 4

January 16, 2020 – Added Savaria Link option to specs, page 4 and provisions by others, page 7

March 18, 2020 – Revised min overhead clearance in specs table on page 4

April 9, 2020 – Added warning on page 5 re floor plug load when not in use

June 17, 2020 – Added 2019 code to list above

February 24, 2021 – Corrected verbiage of unit classification throughout

July 26, 2021 - Updated power requirement

September 20, 2021 - Updated figure on page 6

August 2, 2022 - Updated cover

October 18, 2022 - Added load calculations on page 6

Specifications



NOTE: These specifications are for Telecab17 only. For other sizes with a smaller load capacity, ask your Savaria dealer about the original Telecab (500-lb capacity) described in the original Telecab Planning Guide, P/N 000698.

Telecab17 Specifications

Specification	Specification Data
Load capacity	845 lbs. (384 kg) for 30" x 46" cab and 36" x 54" cab
Maximum travel	23 ft (7.0 m)
Travel speed	20 ft/min (0.1 m/s)
Noise level (for typical installation)	72.9 dBA (up direction); 50.0 dBA (down direction) Measured at a height of 1m, distance of 1m, in front of the motor with all panels on
Daily cycle	Normal: 30 Heavy: 75 Excessive: 100 Maximum starts in 1 hour on standard installation: 12 NOTE: Please consult your Sales Representative if there a chance you may exceed these amounts.
Tower	Modular 8 ft (2.4 m) guide rail assembly with roller guide shoes
Control system	115 VAC relay logic operation 115 VAC up direction and 24 VDC down direction
Levels serviced	2 levels
Platform	Non-skid platform
Power supply (circuit supplied by others)	110 VAC, 20A, 60 Hz, single phase
Lighting supply (circuit supplied by others)	120 volt, 15A, 60 Hz, single phase
Motor/pump	24 VDC, 3 Hp (2.1 kW) Gear type hydraulic pump
Electrical	Automatic battery recharging system (115 VAC) Low voltage controls
Drive system	2:1 roller chain hydraulic
Temperature operating range	-10 °C to +40 °C (14 °F to 104 °F)
Cab access	Front access only (standard)
Cab dimensions	30" x 46" x 80" (762 mm x 1168 mm x 2032 mm) 36" x 54" x 80" (914 mm x 1372 mm x 2032 mm)
Door size	84" x 33.3" (2134 mm x 846 mm) - for 30" x 46" cab 84" x 39.3" (2134 mm x 998 mm) - for 36" x 54" cab
Minimum overhead clearance	96" (2438 mm) to have 6" minimum clearance by code 92" (2337 mm) with variance
Hall calls	Continuous pressure directional push buttons; keyed call/send
Color and finish	White electrostatic powder coat; clear acrylic windows
Safety features	Adjustable top floor presence detector built into the cab Door interlock Hydraulic door closer Underpan safety sensor Emergency stop and alarm Emergency battery lowering Manual emergency lowering Fully-enclosed drive tower Pressure relief valve to prevent platform overload Slack chain safety device Two LED lights in cab Telephone in cab
Options	Battery backup Savaria Link remote monitoring

Site Construction Details

The Telecab17 needs a wall that supports a minimum of 950 lb (4226 N) of pull-out force at any bracket. The floor must be capable of supporting a load of 3200 lb (14,234 N). See Figure 1 below.

A support wall with a combination of either two columns of three 2x4's, two columns of two 2x4's and two 2x6's, or a concrete or brick wall is required. Figure 2 shows the support wall configuration.



WARNING: The maximum load allowed on the floor plug when not in use is 845 lb (384 kg).

Figure 1: Wall/floor loading

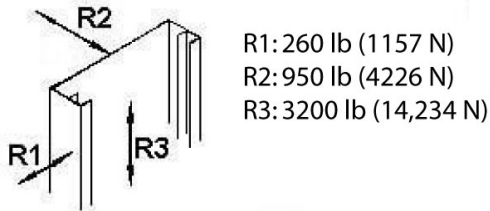
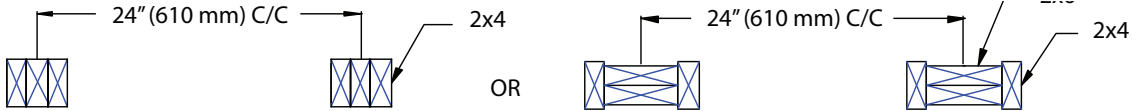

Figure 2: Support wall configuration



Load bearing wall must be able to support a pull-out force of 950 lb (4226 N) at any point.

Call/send station

Tower

Floor cutout needs to support loads shown in Installation Drawings.

Call/send station

The full surface under the lift needs to support a load of 3200 lb (14,234 N).

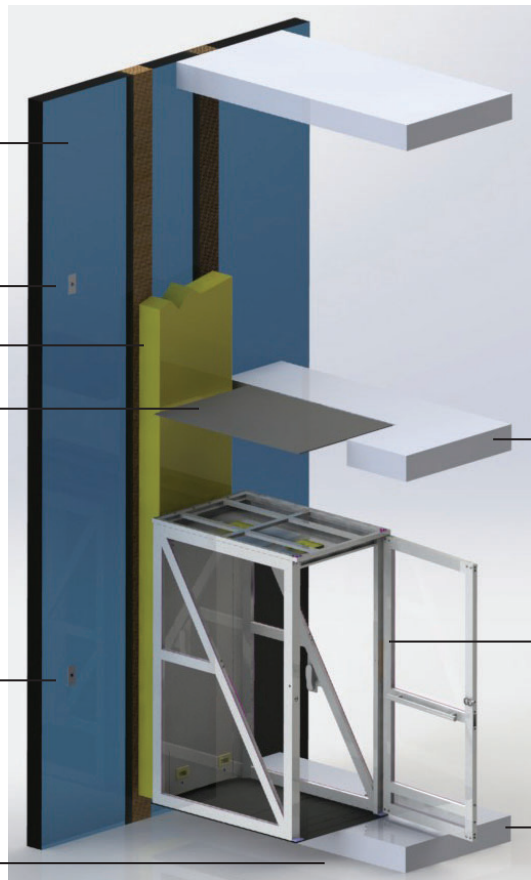

Top landing

Cab

Bottom landing

Load Calculations

CALCULATION FOR TELEcab17 FOR WALL SUPPORT BRACKET								
Telecab Home Lift anchoring loads 36x54 Cab								
42x60" platform, Hydraulic Drive, Hoistway application					For bracket spacing of 36"		No Safety factor	
Lift Model Inches	MAX Tower Weight T (lbf)	-	MAX Car Weight CAR (lbf)	MAX Capacity CAP (lbf)	Support height every 35" after base Last position H in inches	MAX Wall Support loads per mounting points (doubles the values = per bracket) Ra = Rb (lbf)	Pit load With support legs P (lbf)	Estimated Impact load R3 (lbf)
96	936		700	845	138	764	2481	6981
108	995		700	845	160	764	2540	6981
120	1037		700	845	172	764	2582	6981
144	1145		700	845	196	764	2690	6981
168	1314		700	845	218	764	2859	6981
192	1425		700	845	242	764	2970	6981
216	1541		700	845	266	764	3086	6981
240	1649		700	845	290	764	3194	6981
264	1758		700	845	312	764	3303	6981
276	1814		700	845	326	764	3359	6981

Elevation View

The following illustration shows the general elevation view and dimensions of the Telecab17.

Note that the minimum overhead is 96" (2438 mm) for 80" (2032 mm) inside height cab dimension.

Refer to your site-specific Installation Drawings for details relevant to your job site.

Figure 3: Elevation view and dimensions

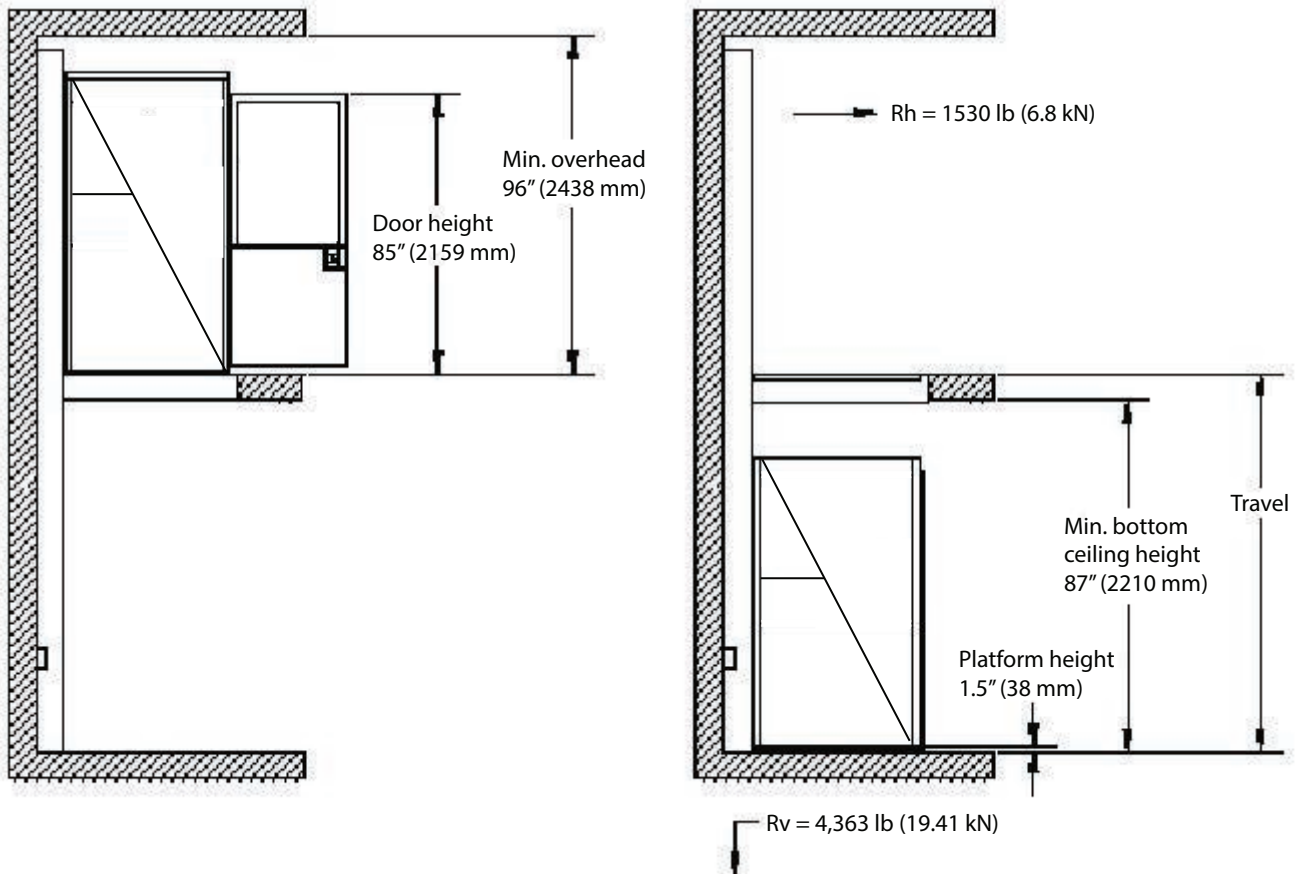

Cab Types

Cab types and sizes are listed below. Always refer to your site-specific Installation Drawings for details.

- Type 5 – 30" x 46" x 80", front access only
- Type 5 – 36" x 54" x 80", front access only

Figure 4: Type 5 cab (front access only)

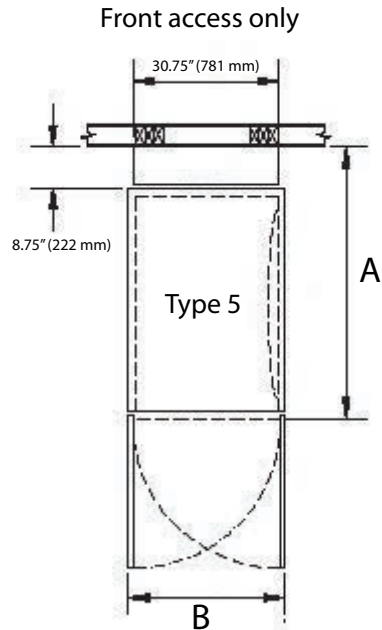

Provisions by Others - Savaria Link Option

If you have the Savaria Link Ethernet remote monitoring option, ensure that you have an Ethernet connection with Internet capability in the vicinity of the unit's controller.

If you have the Savaria Link Wireless remote monitoring option, ensure that you have a wireless signal with Internet capability in the vicinity of the unit's controller.

Drawings

The following page shows installation drawings for both sizes of the Telecab17.



NOTE: These specifications are for Telecab17 only. For other sizes with a smaller load capacity, ask your Savaria dealer about the original Telecab (500-lb capacity) described in the original Telecab Planning Guide, P/N 000698.

Figure 6: Type 5 – 30" x 46" x 80", front access only

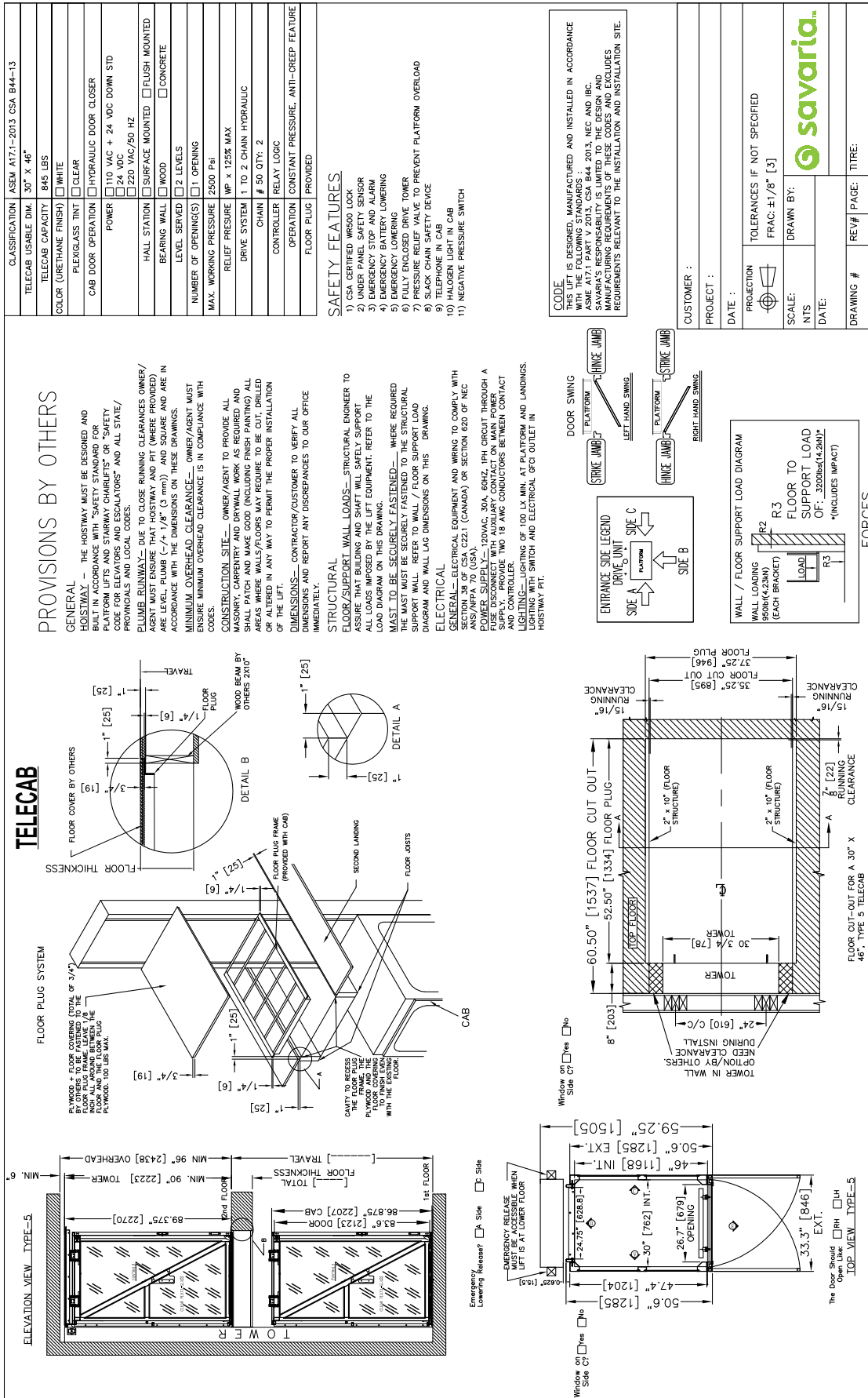

Find more design resources at:

savaria.com

[CAD drawings](#)

[BIM objects](#)

[SpecWizard](#)

[Continuing education calendar](#)

Savaria Concord Lifts, Inc.
2 Walker Drive Brampton ON L6T 5E1 Canada

 **savaria.**
savaria.com

©2022 Savaria Corporation