



Multilift PUBLIC

VERTICAL PLATFORM LIFT

PLANNING GUIDE

Applicable Codes:

ASME A17.1

ASME A18.1

CSA B613

CSA B355-09

**Part No. 000790
25-m08-2020**

Purpose of this guide

This guide assists architects, contractors, and lift professionals to incorporate the Multilift Vertical Platform Lift into a residential or public building design. The design and manufacture of the Multilift Vertical Platform Lift meets the requirements of the following codes and standards:

- ASME A18.1-2003 Section 2 (Public)
- ASME A18.1-2005 Section 2 (Public)
- ASME A18.1-2008 Section 2 (Public)
- ASME A18.1-2011 Section 2 (Public)
- ASME A18.1-2014 Section 2 (Public)
- ASME A18.1-2017 Section 2 (Public)
- CAN/CSA B355 S1-02 (Public)
- CAN/CSA-B355-09 (Public)
- CAN/CSA B613-2000 (Public)

We recommend that you contact your local authority having jurisdiction to ensure that you adhere to all local rules and regulations pertaining to vertical platform lifts.

IMPORTANT NOTICE

This Planning Guide provides nominal dimensions and specifications useful for the initial planning of a vertical platform lift project. Dimensions and specifications are subject to change without notice due to continually evolving code and product applications.

Before beginning actual construction, please consult Savaria or the authorized Savaria dealer in your area to ensure you receive your site-specific installation drawings with the dimensions and specifications for your project.

Visit our website (www.savaria.com) for the most recent Multilift drawings and dimensions.

How to use this guide

- 1 Determine your client's intended use of the lift.
- 2 Determine the local code requirements.
- 3 Determine the site installation parameters.
- 4 Determine the cab type and hoistway size requirements.
- 5 Plan for electrical requirements.

History

December 20, 2010 - Initial release

February 24, 2011 - Added information for automatic access ramp to "Features" in Specifications table on pg. 6

June 1, 2011 - Updated drawings for Type 3 and Type 4 with platform gate; added drawings for Type3-42 and Type 4-42 with platform gate

April 25, 2013 - Correct power supply amperage from 20A to 15A in specifications table on pg. 6

July 8, 2013 - Added Noise Level to specifications table on pg. 6

December 5, 2013 - Added B355-09 spec to title page; added 42x48, 42x54 and 42x60 cab sizes to specifications table on pg. 6; added 42x48, 42x54 and 42x60 cab sizes to list of drawings on page 12 and a NOTE that the 42" wide cab sizes are not self-supporting and need wall mounting; added new drawings on pages 14, 16, 18, 20, 22, 24, 26 and 28

December 17, 2013 - Added "must be a dedicated electrical line" to power supply specification in table on pg. 6

March 13, 2014 - Revised "Drive System" in Specifications table on pg. 6

December 11, 2014 - Changed title to reflect PUBLIC and added codes on page 3

January 19, 2015 - Added new 2014 code to section above; Added new 3-gate drawings on page 33 and 34

September 24, 2015 - Added Daily Cycle to specifications table on page 6

March 7, 2016 - Removed copyright from cover page; Savaria Corporation back to Savaria Concord Lifts, Inc.

March 28, 2016 - Revised Power Supply spec in table on page 6

April 20, 2016 - Added warning to slab drawing on page 8; Added drawings to show tower support brackets on pages 11, 12 and 13

May 31, 2016 - Revised Drive System spec in table on page 6

February 16, 2017 - Revised temperature spec in specs table on page 6

September 27, 2018 - Added ASME 18.1-2017 to code list above

January 8, 2019 - Added spec for distance between 2 landings on page 6

April 8, 2019 - Revised text on page 10

May 6, 2020 - Added Savaria Link option to specs table on page 6 and provisions by others on page 41

August 25, 2020 - Added mobile drawings on pages 41 and 42

Description

The Multilift Vertical Platform Lift is designed to provide easy access from one landing to another. The versatile design of this lift can be adapted to most architectural requirements and its rugged construction allows for outdoor or indoor use. It is an ideal deck lift for home use and is also approved for certain commercial accessibility projects as well. The Multilift, with its ACME screw drive system, provides safe and reliable operation.

Lift components

The Multilift consists of a tower and a platform as shown in Figure 1.

Figure 1: Typical lift

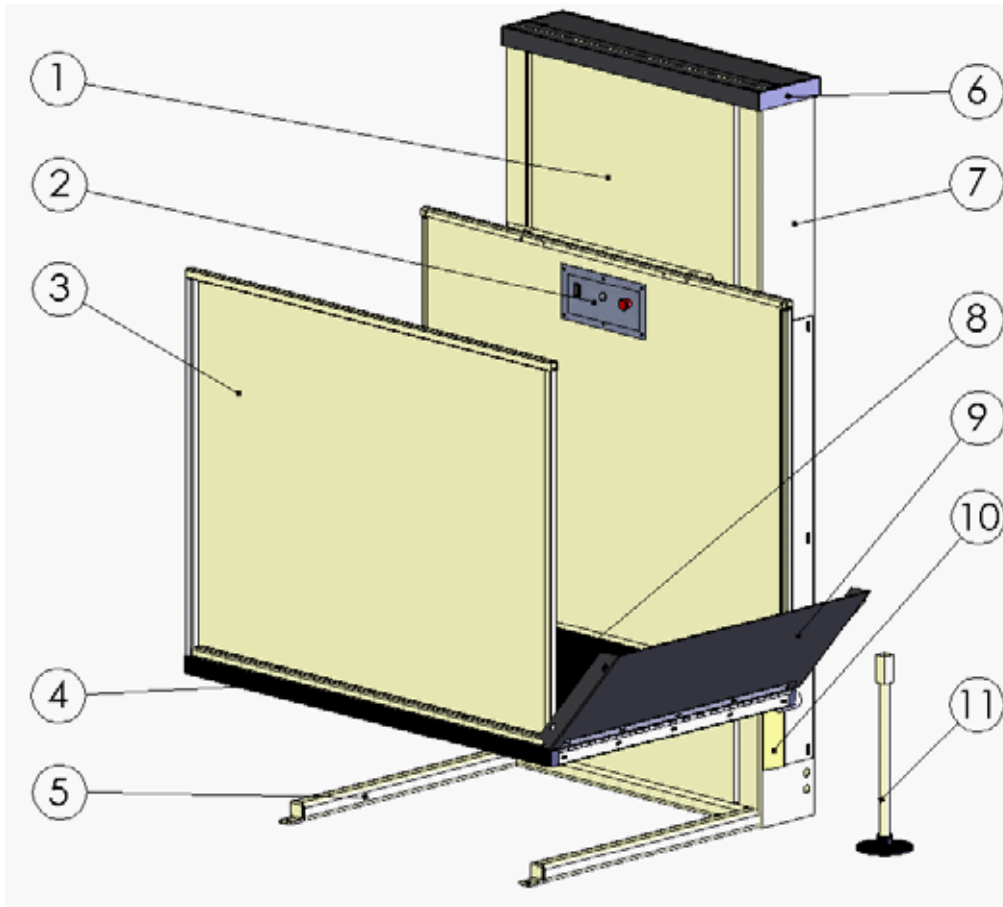

Number	Description	Number	Description
1	Front tower panel	7	Tower
2	Car operating panel (C.O.P.)	8	Non-skid platform
3	Side guard panel	9	Automatic access ramp
4	Safety underpan sensors	10	Access ramp channel
5	Self support base	11	Manual lowering device
6	Tower cover	-	-

Drive tower components

The Multilift drive tower components are shown in Figure 2.

Figure 2: Drive tower

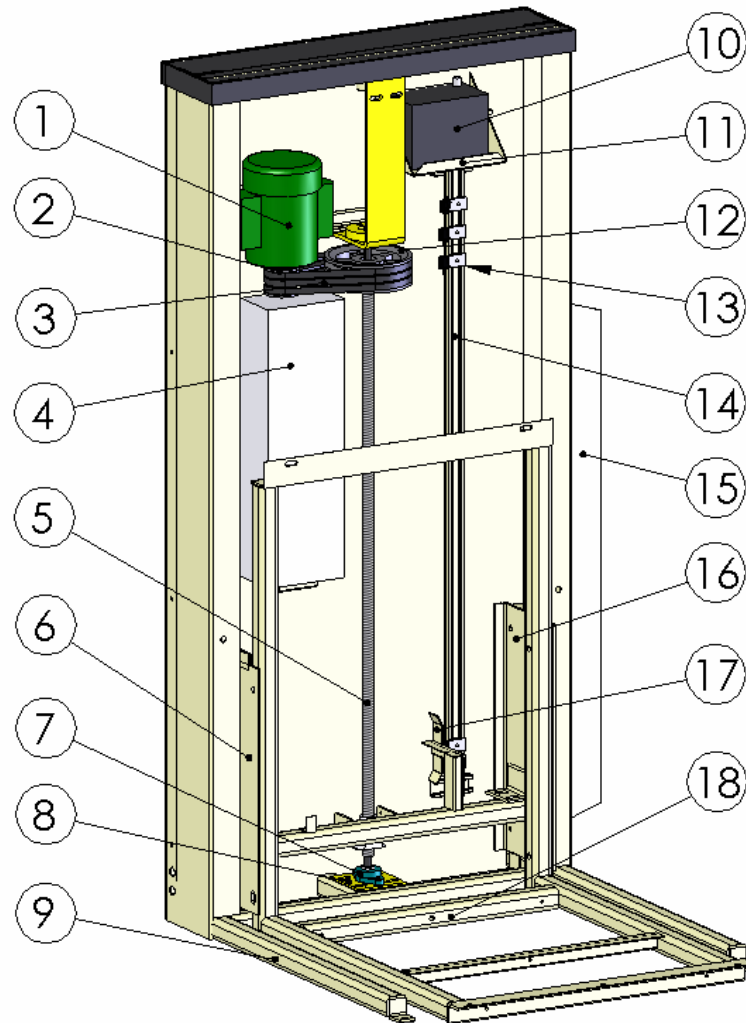

Number	Description	Number	Description
1	Motor	10	Battery (optional)
2	Main pulley	11	Battery tray
3	V strap	12	Pulley
4	Controller box	13	Limit switches (may vary)
5	Acme screw	14	Unistrut
6	Left roller guide	15	Access ramp channel
7	Lower bearing	16	Right roller guide
8	Lower bearing plate	17	Cam assembly
9	Self support base	18	Carriage assembly

Specifications

Multilift specifications

Applications	Residential (indoor/outdoor)
Load capacity	750 lb (340 kg)
Maximum travel distance	48" (1219 mm); optionally 72" (1829 mm)
Levels serviced	2
Distance between 2 landings	8" (203 mm) minimum
Travel speed	8 ft/min (0.04 m/s)
Temperature	-20 °F to +122 °F (-29 °C to +50 °C)
Noise level (for typical installation)	65.9 dBA (up direction); 65.0 dBA (down direction) Measured at a height of 1m, distance of 1m, in front of the motor with all panels on
Daily cycle	Normal: 10 Heavy: 25 Excessive: 40 Maximum starts in 1 hour on standard installation: 10 NOTE: Please consult your Sales Representative if there a chance you may exceed these amounts.
Cab types/sizes	Type 2, 3 or 4 <ul style="list-style-type: none"> • 36" x 48" (914 mm x 1219 mm) • 36" x 54" (914 mm x 1371 mm) • 36" x 60" (914 mm x 1524 mm) • 42" x 48" (1067 mm x 1219 mm) • 42" x 54" (1067 mm x 1371 mm) • 42" x 60" (1067 mm x 1524 mm) NOTE that the 42" wide cab units are not self-supporting and need wall mounting.
Side guard panels	42 1/8" (1070 mm) side guard panels on platform
Cab access	Front/rear access - standard (platform Type 2) 90 degree access - optional (platform Type 3 and 4)
Power supply	120 VAC, 20 A, 60 Hz, single phase (must be a dedicated electrical line)
Drive system	Acme screw and back-up nut Standard: 1 hp (0.74 Kw) motor, 110 VAC model Optional: 1 hp (0.74 Kw) motor, 24-volt battery model
Control system	Electronic-free relay logic controller
Finish	Beige electrostatic powder coat paint on all steel surfaces and vacuum-formed plastics
Features	Call/send stations at landings Continuous-pressure type buttons Operating control buttons on platform Emergency manual lowering/raising device Low-voltage controls Underpan sensors Non-skid platform surface Automatic access ramp (24"); field reversible to suit installation needs Emergency stop button
Options	Savaria Link remote monitoring

Site construction details

The self-supporting base must be able to support at least 3000 lb (13.3 kN) per Figure 3 and must be anchored to a concrete slab (or floor) per Figure 4. Make sure the slab (floor) surface is level.

Figure 3: Floor loading diagram

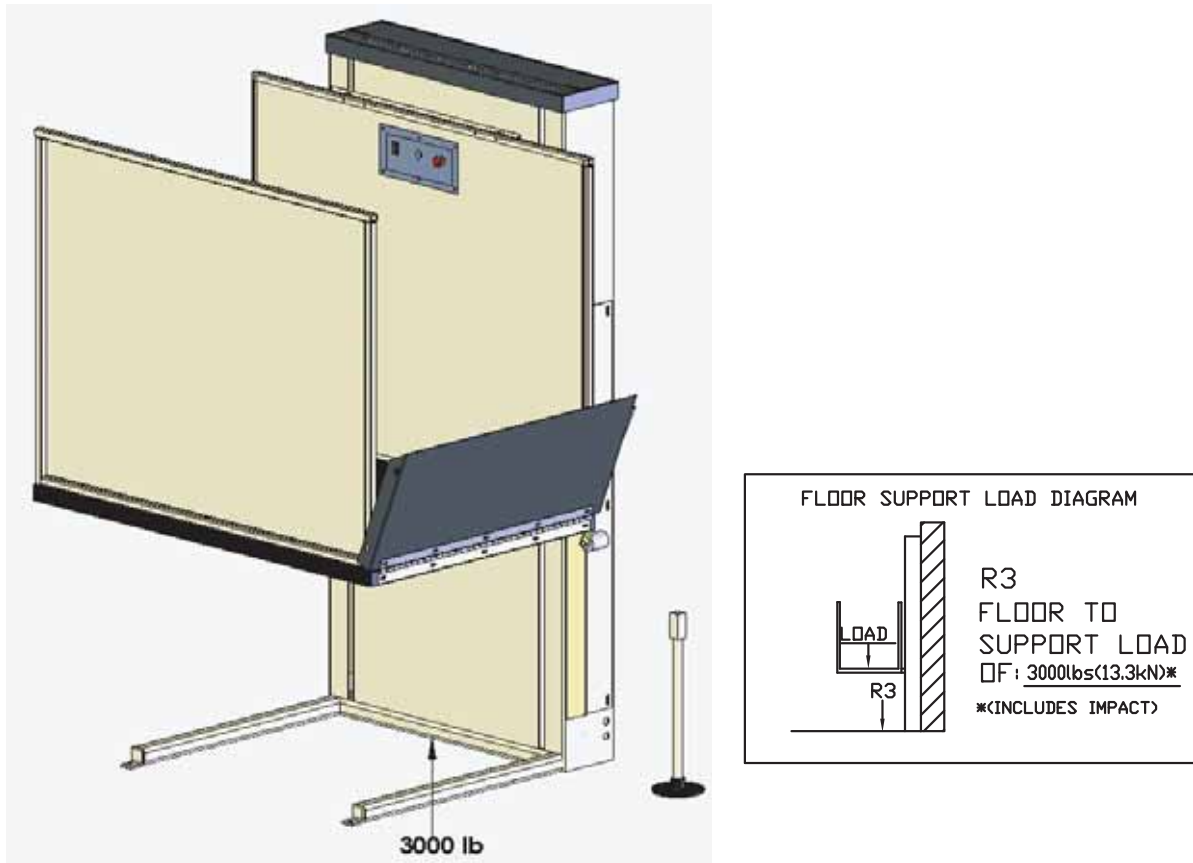

Figure 4: Anchor points

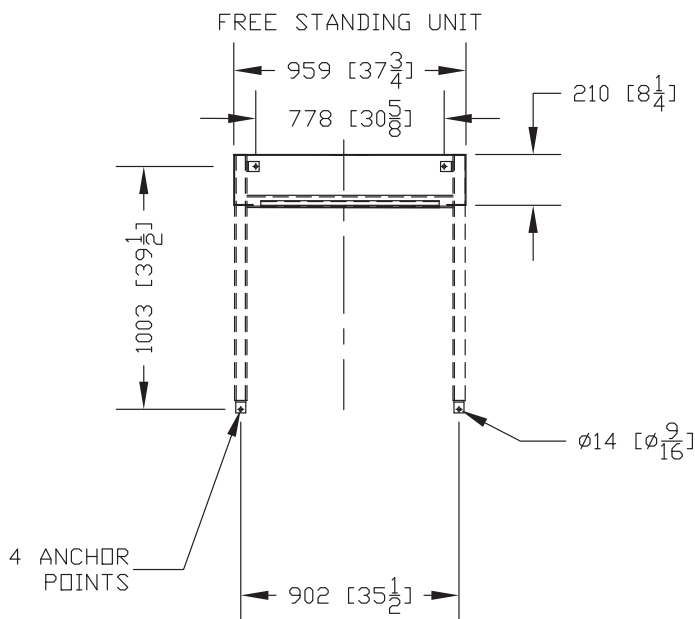
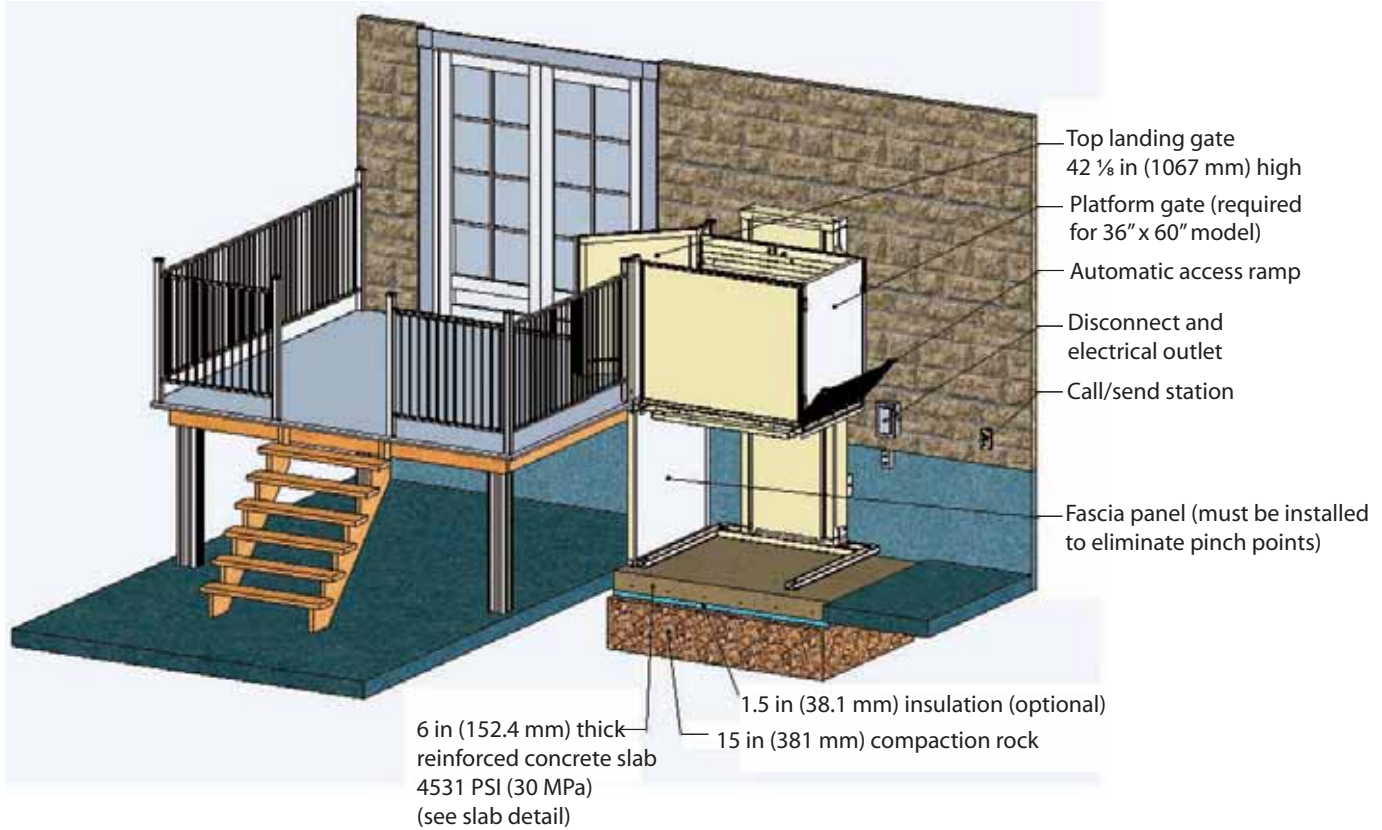

Figure 5 illustrates the site construction details for a typical outdoor application.

Figure 5: Sample unenclosed outdoor application



Outdoor applications need a strong and stable surface that will not move throughout the years. For this reason, it is essential, when the temperature can get below the freezing point, to insert an insulate sheet between the concrete slab and the compaction rock. Figure 6 illustrates the concrete slab detail for a typical outdoor application.

Figure 6: Concrete slab detail

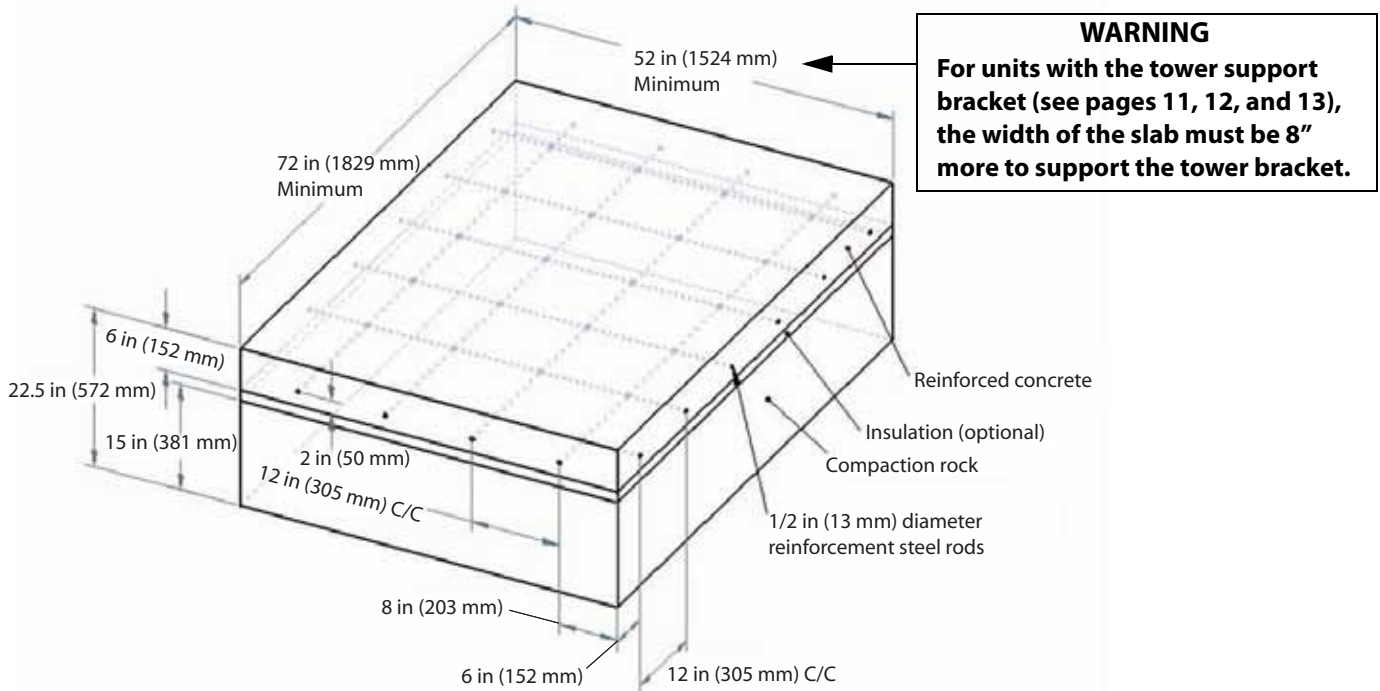

Landing gate/door details

Landing gate/door details are specific to each job site. Be sure to refer to your site-specific installation drawings.

There are two options that can be used when preparing for installation of the gate (or door with sill angle). Figure 7 illustrates the two options for a gate. Refer to the Installation Guide for details on installing the landing gate or door.

- Option 1 – Notch out the landing so that the gate angle bracket (or door sill angle) is flush with the vertical landing surface.
- Option 2 – Install a 1/4" fascia panel to fill in the gap in the vertical landing surface from underneath the gate angle bracket (or door sill angle) down to the floor/ground. If your site has a hoistway or pit, be sure to add 1/4" to those dimensions to account for the 1/4" fascia panel.

Figure 7: Options used when installing a gate

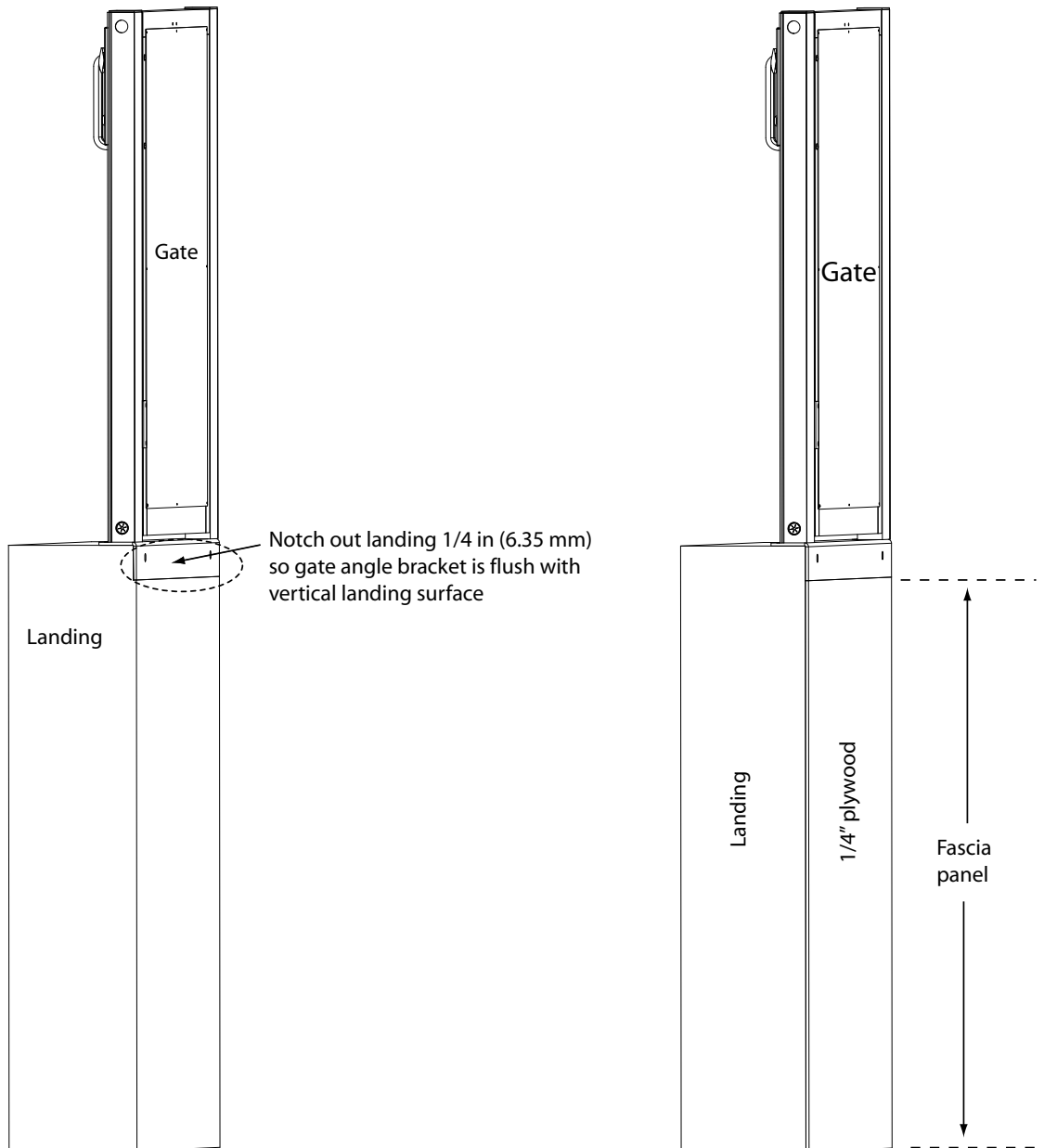

Notch out landing to install gate

Install fascia panel for gate

Commercial requirements

For hoistway applications, please see Figure 8 below. Also required are the following:

- Grab bar (hand rail)
- Emergency light on platform
- Controller redundancy
- Emergency stop/alarm
- Hoistway
- Top landing gate or door
- Disconnect (provided by others)
- Door locks

Figure 8: Hoistway requirements

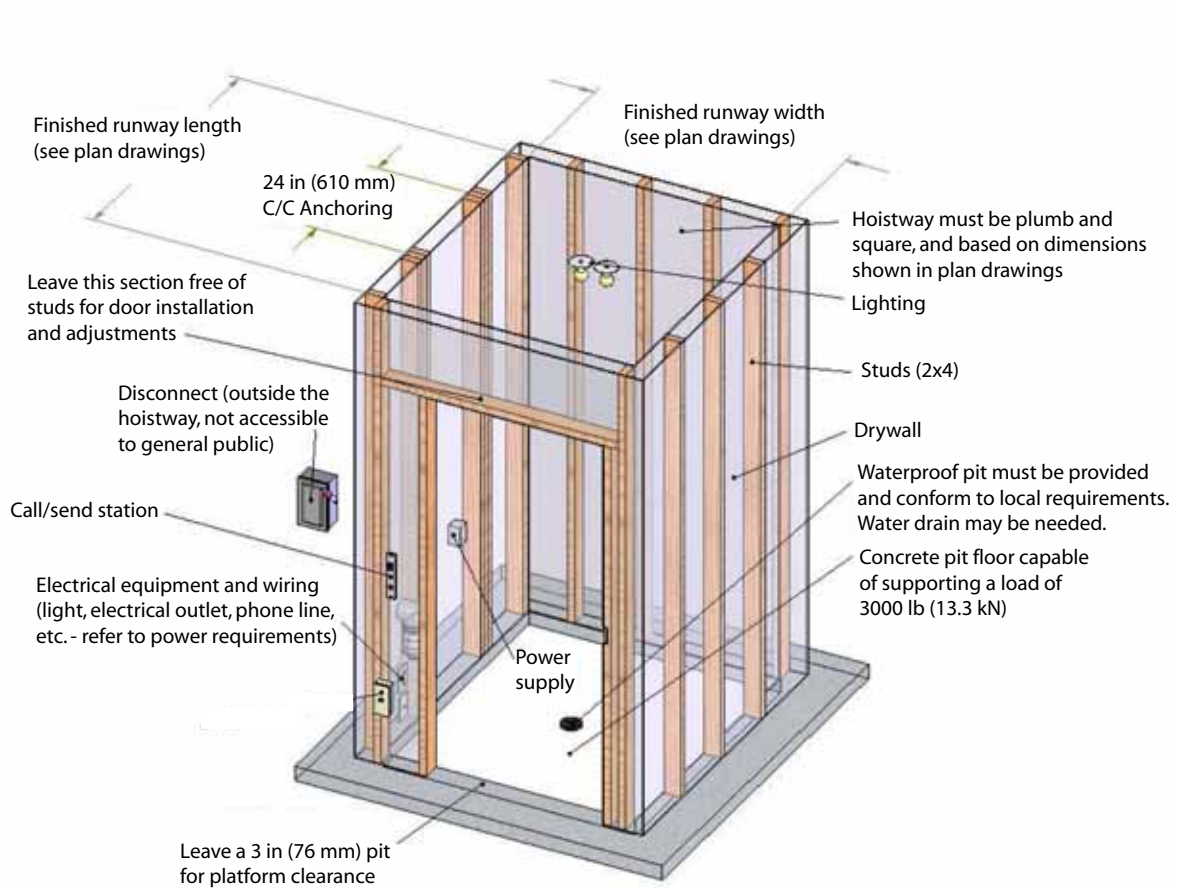

Tower support bracket (commercial units)

For commercial units without a support wall, there is a tower support bracket (see Figures 9, 10 and 11) that must be installed behind the tower for extra support. The dimensions of this bracket are shown in the drawing below.

Figure 9: Tower support bracket

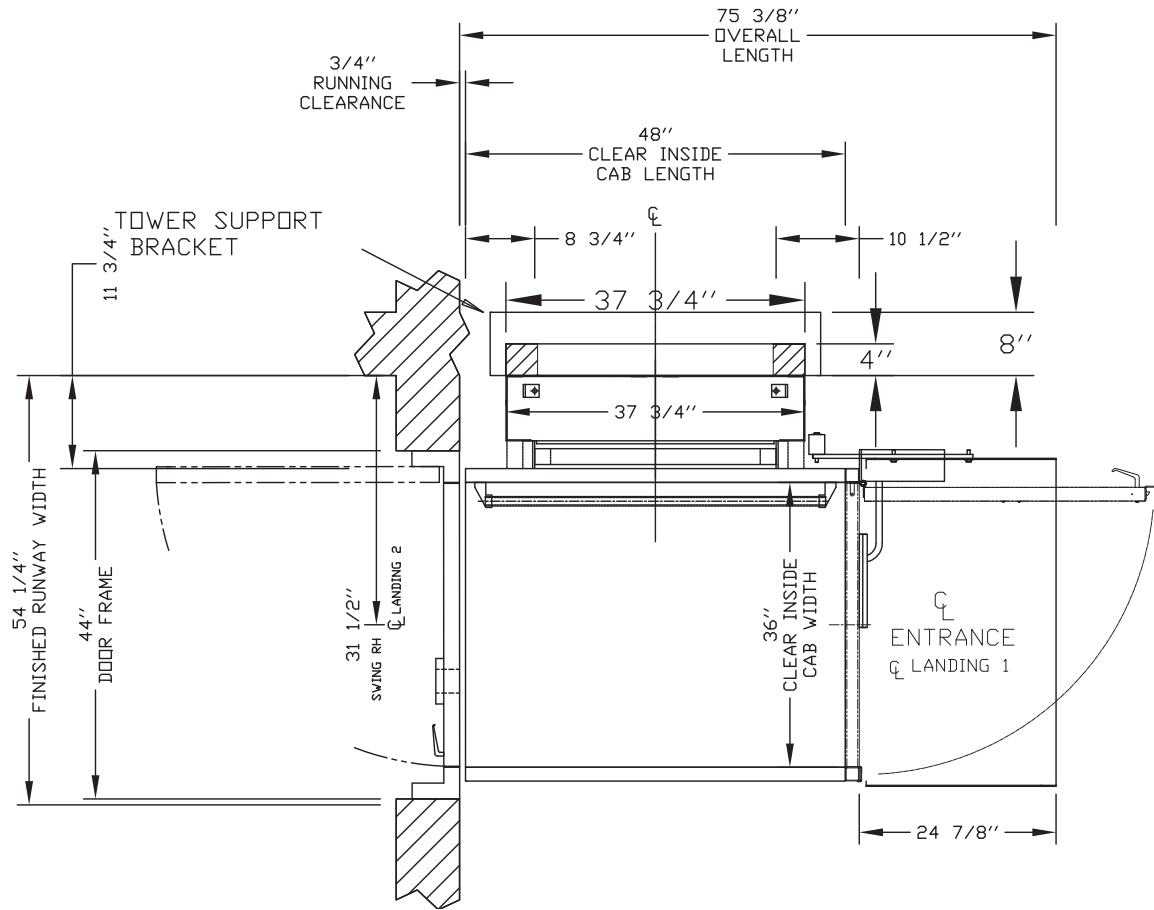

Figure 10: Tower support bracket (low tower)

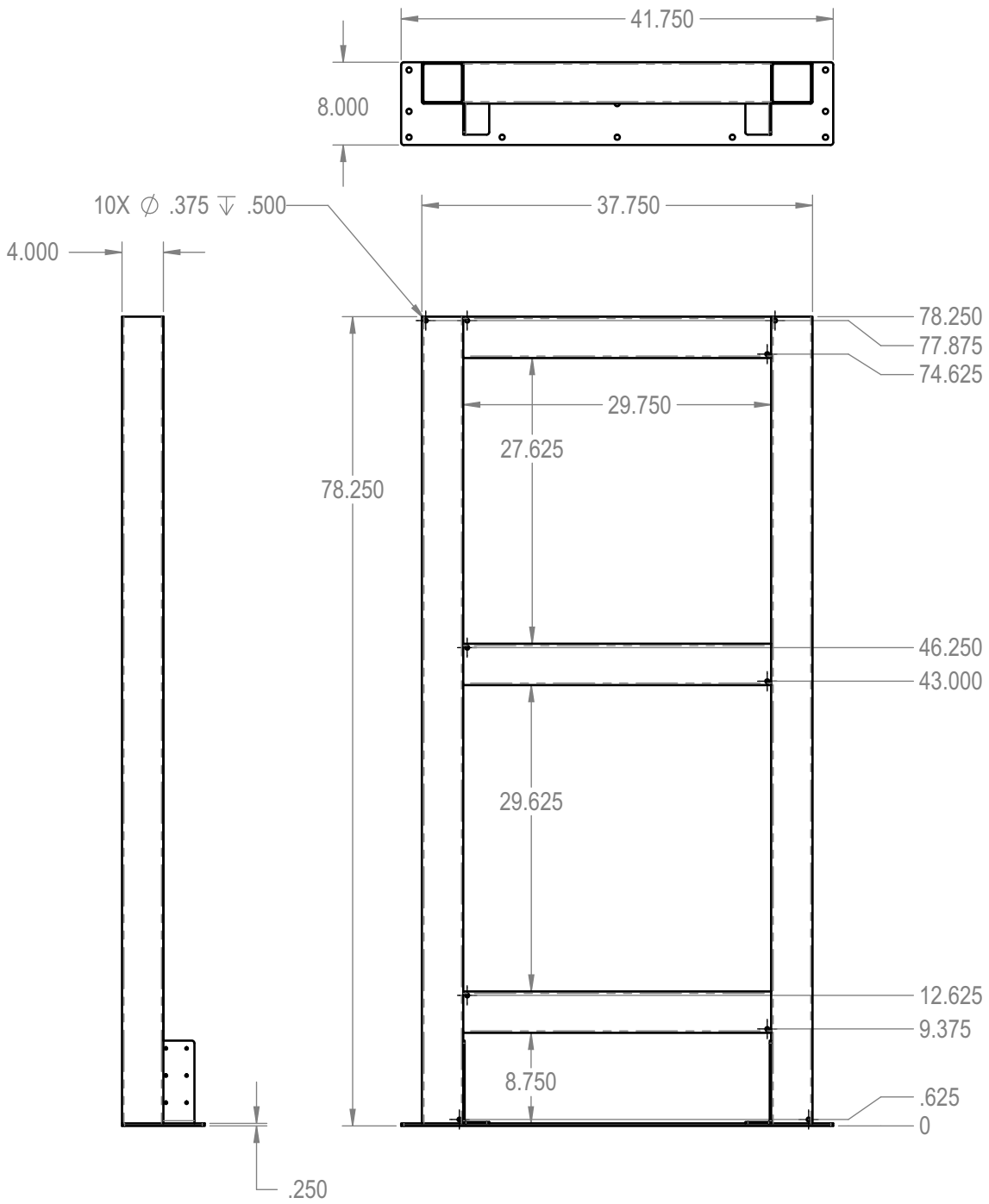
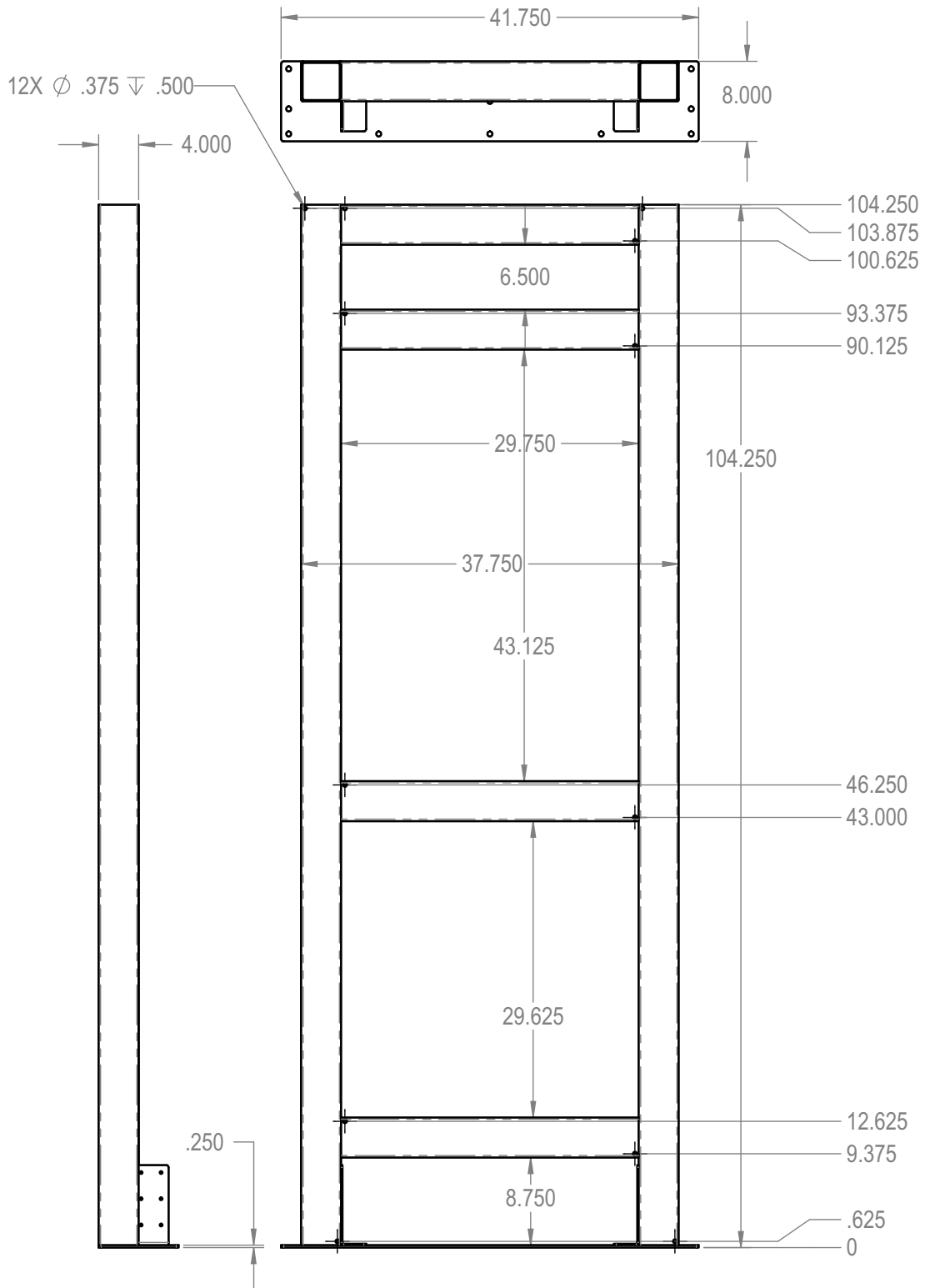

Figure 11: Tower support bracket (tall tower)



Load calculations

SAVARIA Multilift								
Vertical Platform Lift Anchoring Loads (worst case scenario)								
36x60" Platform, Screw Drive, Hoistway Application						No Safety Factor		
Lift Model (inches)	MAX Tower Weight T (lbs)	-	MAX Car Weight CAR (lbs)	MAX Capacity CAP (lbs)	n/a	n/a	Pit Load P (lbs)	Estimated Impact Load R3 (lbs)
48	500		400	750	N/A	N/A	1650	3000
60	650		400	750	N/A	N/A	1800	3000
72	650		400	750	N/A	N/A	1800	3000

N.B.

Calculations do not include forces due to wind, seismic loading, any environmental loading and forces due to acceleration.

Calculations are assuming that the unit is self supported.

A minimum Safety Factor of 4 is recommended; check local code requirements or building special requirements.

The average standard cab weight is 350 lbs; the values vary accordingly.

If the building doesn't allow bracket mounting spacing of 36", R2 needs to be increased accordingly.

The Impact Load is not "necessary" if the lift is installed properly and maintained according to the manufacturer's recommendation. If the unit is ordered with base legs, the Pit Load related to cab weight and capacity will be spread on the footprint.

Vertical Platform Lift Anchoring Loads (worst case scenario)								
36x60" Platform, Screw Drive, Hoistway Application						No Safety Factor		
Lift Model (inches)	MAX Tower Weight T (lbs)	MAX Enclosure Weight T (lbs)	MAX Car Weight CAR (lbs)	MAX Capacity CAP (lbs)	Anchor on the wall for tall travel	MAX Wall Support Loads per mounting points (double the values = per bracket) R2 (lbs)	Pit Load P (lbs)	Estimated Impact Load R3 (lbs)
48	500	625	400	750			2275	3000
60	650	675	400	750	102	472	2475	3000
72	650	725	400	750	102	472	2525	3000

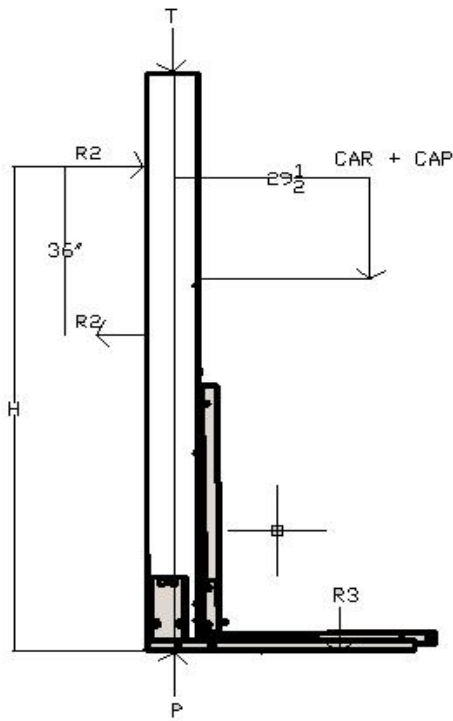

Cab types

Type 2 cab (standard)

For type 2 cabs, entry and exit are available from both ends of the platform.

Figure 12: Type 2

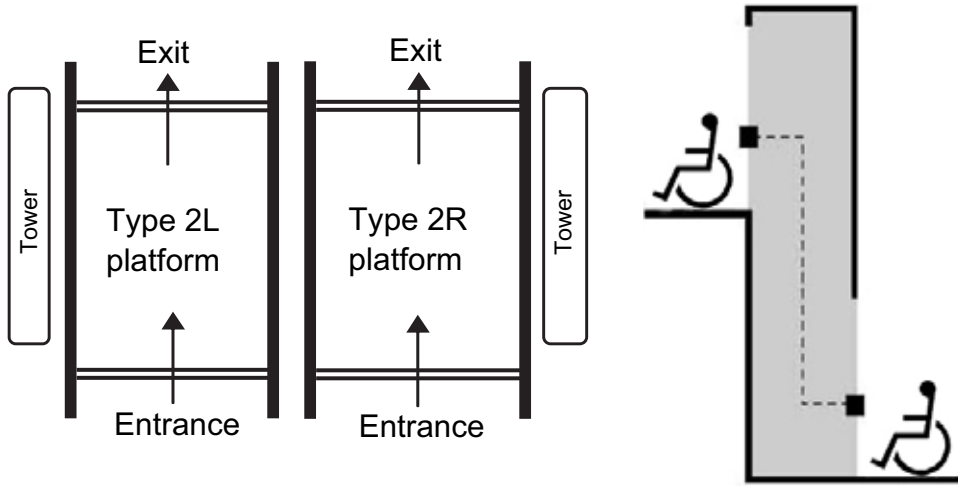

Type 3 and 4 cab (optional)

For type 3 and 4 cabs, entry and exit are available from one end and one side of the platform.

Figure 13: Type 3 and 4

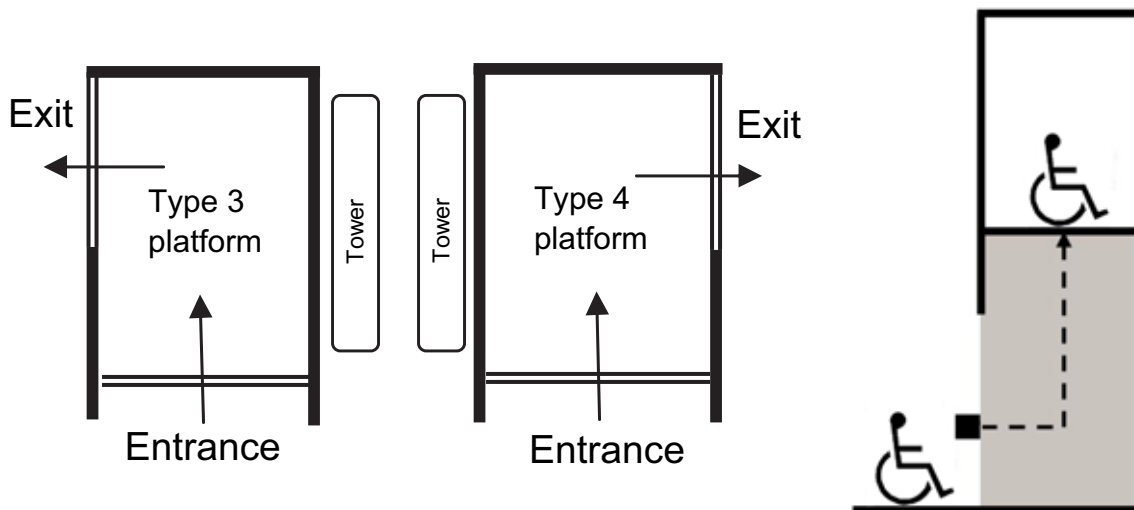

Drawings

The next several pages provide various Multilift drawings. Always refer to your installation drawings for details specific to your site.

Elevation and plan view drawings (for the different cab types and sizes):

- Type 2 without platform gate – 36" x 54"
- Type 2 without platform gate – 42" x 48", 42" x 54", 42" x 60"
- Type 3 without platform gate – 36" x 54"
- Type 3 without platform gate – 42" x 48", 42" x 54", 42" x 60"
- Type 4 without platform gate – 36" x 54"
- Type 4 without platform gate – 42" x 48", 42" x 54", 42" x 60"
- Type 2 with platform gate – 36" x 54", 36" x 60"
- Type 2 with platform gate – 42" x 54", 42" x 60"
- Type 3 with platform gate – 36" x 54", 36" x 60"
- Type 3 (42" B side opening) with platform gate – 36" x 60"
- Type 3 (42" B side opening) with platform gate – 42" x 60"
- Type 4 with platform gate – 36" x 54", 36" x 60"
- Type 4 with platform gate – 42" x 54", 42" x 60"
- Type 4 (42" B side opening) with platform gate – 36" x 60"
- Type 2, enclosure, 36" x 48", 36" x 54", 36" x 60"
- Type 2, enclosure, 42" x 48", 42" x 54", 42" x 60"
- Type 3, enclosure, 36" x 48", 36" x 54", 36" x 60"
- Type 3, enclosure, 42" x 48", 42" x 54", 42" x 60"
- Type 4, enclosure, 36" x 48", 36" x 54", 36" x 60"
- Type 4, enclosure, 42" x 48", 42" x 54", 42" x 60"
- Type 2 with 3 gates (RH)– 36" x 54"
- Type 2 with 3 gates (LH) – 36" x 54"

NOTE that the 42" wide cab units and B355 units are not self-supporting and need wall mounting.

Two sample landing gate layout drawings are provided:

- 42" x 36" auto left-hand gate
- 42" x 36" manual left-hand gate
- Mobile Multilift drawings

Note: For specifications on other landing gates and doors, go to our website www.savaria.com, select the "architects and builders" tab at the top of the page and then select "Doors and Gates" from the menu on the left-hand side of the page.

The link is as follows: <http://www.savaria.com/architects/drawings/doors-gates/index.php>.

Figure 14: Elevation and plan view – type 2 without platform gate – 36" x 54"

ELEVATION VIEW TYPE-2

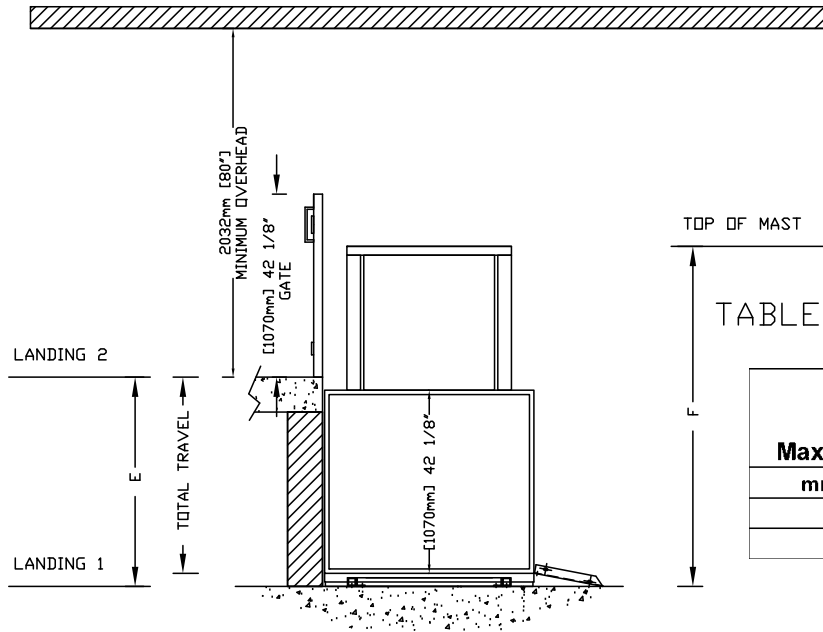

TABLE 1 – MAST HEIGHT

E Max.Travel	F Mast Height with 2" CAP	
	mm (Inches)	mm Inches
1219 (48")	2032	80
1829 (72")	2642	104

TOP VIEW TYPE-2

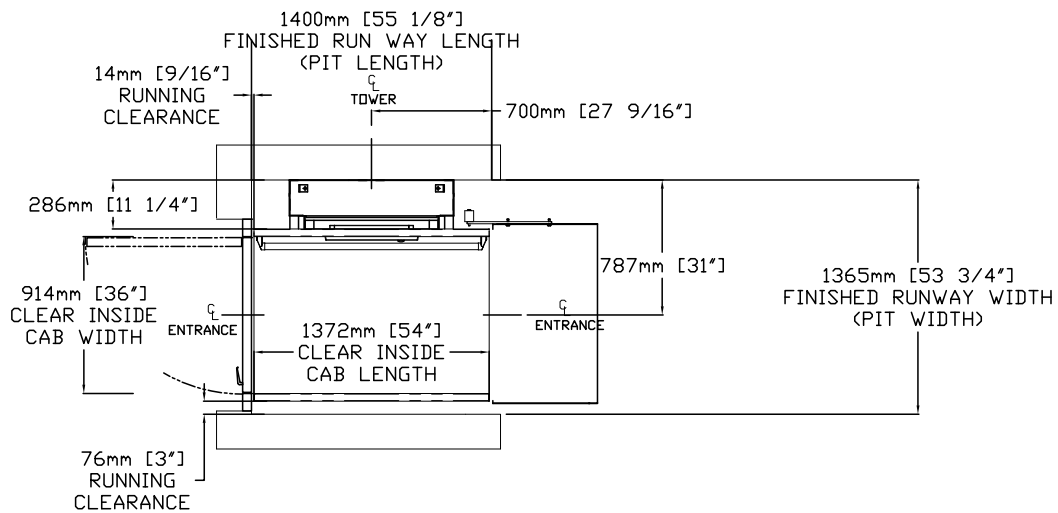

Figure 15: Elevation and plan view – type 2 without platform gate – 42" x 48", 42" x 54", 42" x 60"

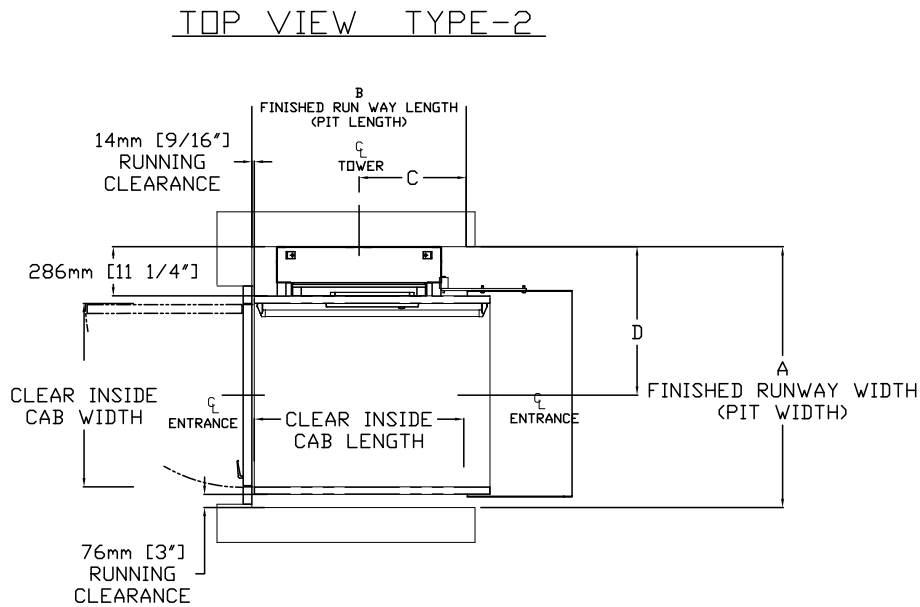
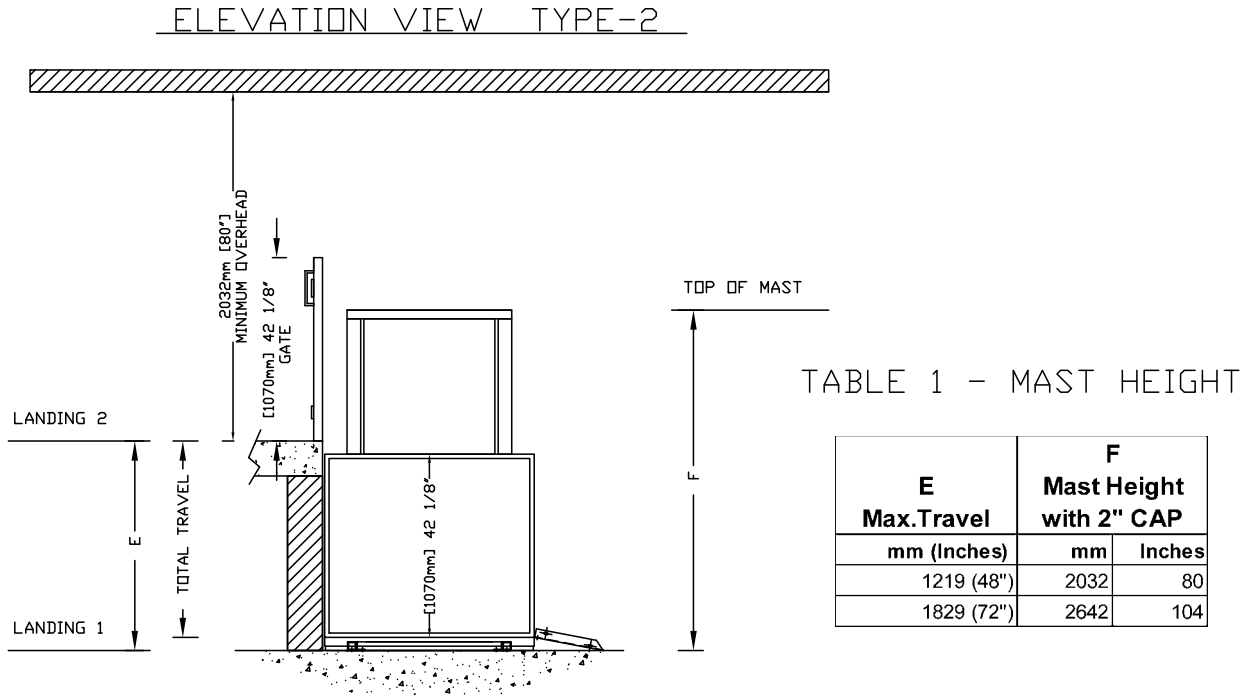

TABLE 2- HOISTWAY DIMENSION

CLEAR INSIDE CAB WIDTH		CLEAR INSIDE CAB LENGTH		A FINISHED RUNWAY WIDTH		B FINISHED RUNWAY LENGTH		C TOWER CENTER LINE		D DOOR CENTER LINE (IN CASE OF 42" DOOR)	
mm	Inches	mm	Inches	mm	Inches	mm	Inches	mm	Inches	mm	Inches
1067	42	1219	48	1511	59 1/2	1248	49 1/8	624	24 9/16	864	34
1067	42	1372	54	1511	59 1/2	1400	55 1/8	700	27 9/16	864	34
1067	42	1524	60	1511	59 1/2	1553	61 1/8	776	30 9/16	864	34

Figure 16: Elevation and plan view – type 3 without platform gate – 36" x 54"

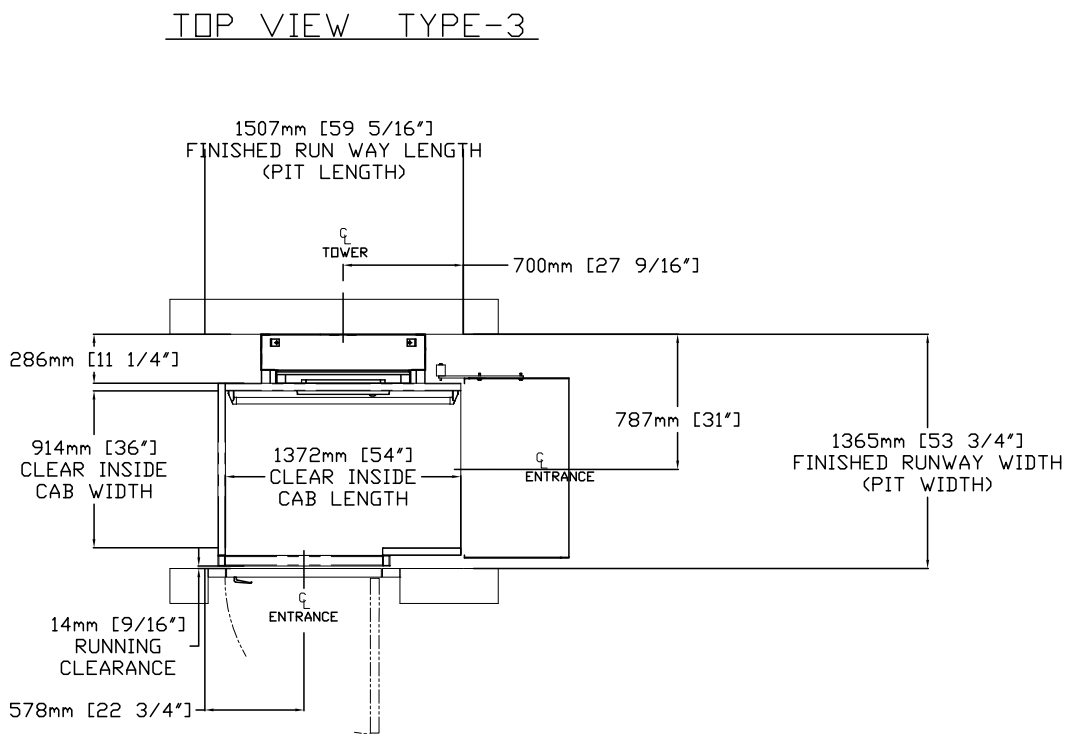
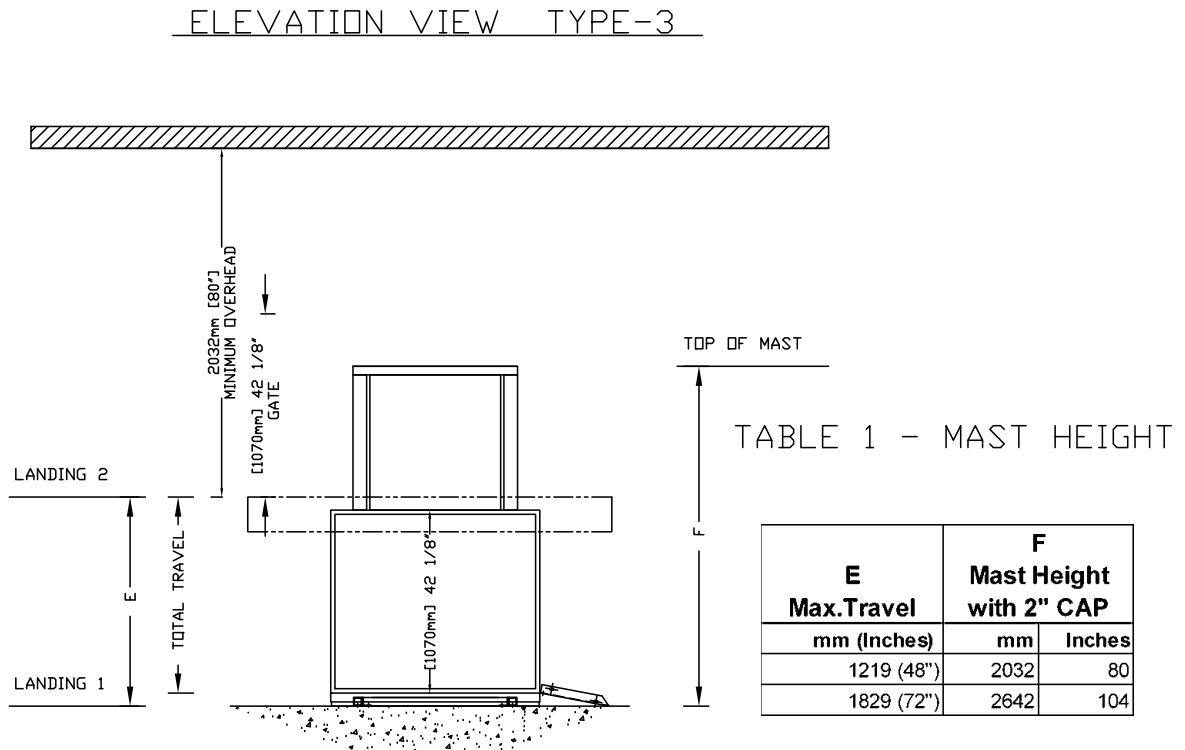

Figure 17: Elevation and plan view – type 3 without platform gate – 42" x 48", 42" x 54", 42" x 60"

ELEVATION VIEW TYPE-3

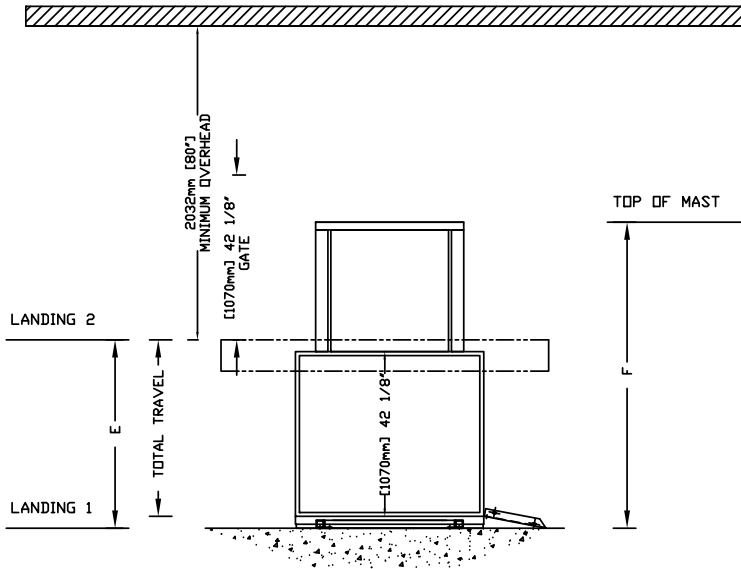

TABLE 1 – MAST HEIGHT

E Max.Travel	F Mast Height with 2" CAP	
	mm (Inches)	mm Inches
1219 (48")	2032	80
1829 (72")	2642	104

TOP VIEW TYPE-3

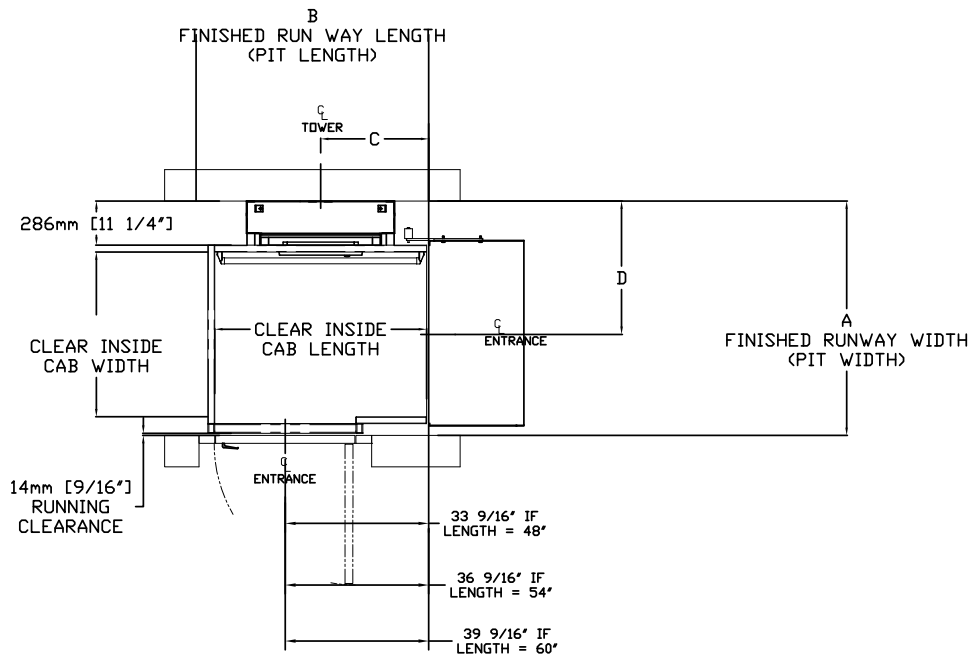

TABLE 2- HOISTWAY DIMENSION

CLEAR INSIDE CAB WIDTH		CLEAR INSIDE CAB LENGTH		A FINISHED RUNWAY WIDTH		B FINISHED RUNWAY LENGTH		C TOWER CENTER LINE		D DOOR CENTER LINE (IN CASE OF 42" DOOR)	
mm	Inches	mm	Inches	mm	Inches	mm	Inches	mm	Inches	mm	Inches
1067	42	1219	48	1518	59 3/4	1354	53 5/16	624	24 9/16	864	34
1067	42	1372	54	1518	59 3/4	1507	59 5/16	700	27 9/16	864	34
1067	42	1524	60	1518	59 3/4	1659	65 5/16	776	30 9/16	864	34

Figure 18: Elevation and plan view – type 4 without platform gate – 36" x 54"

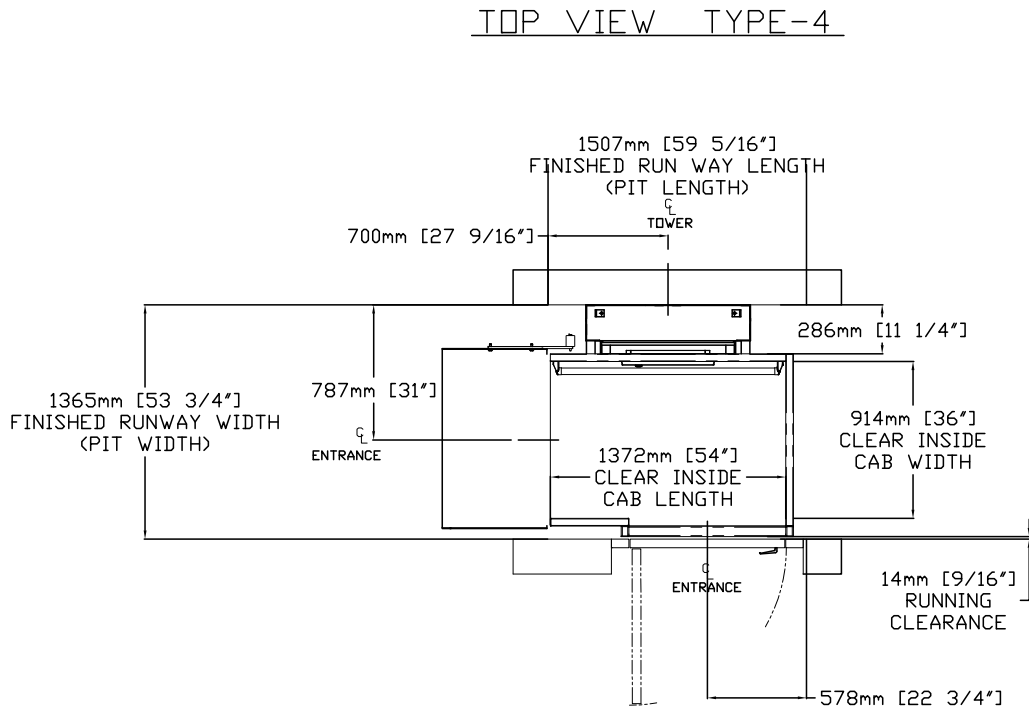
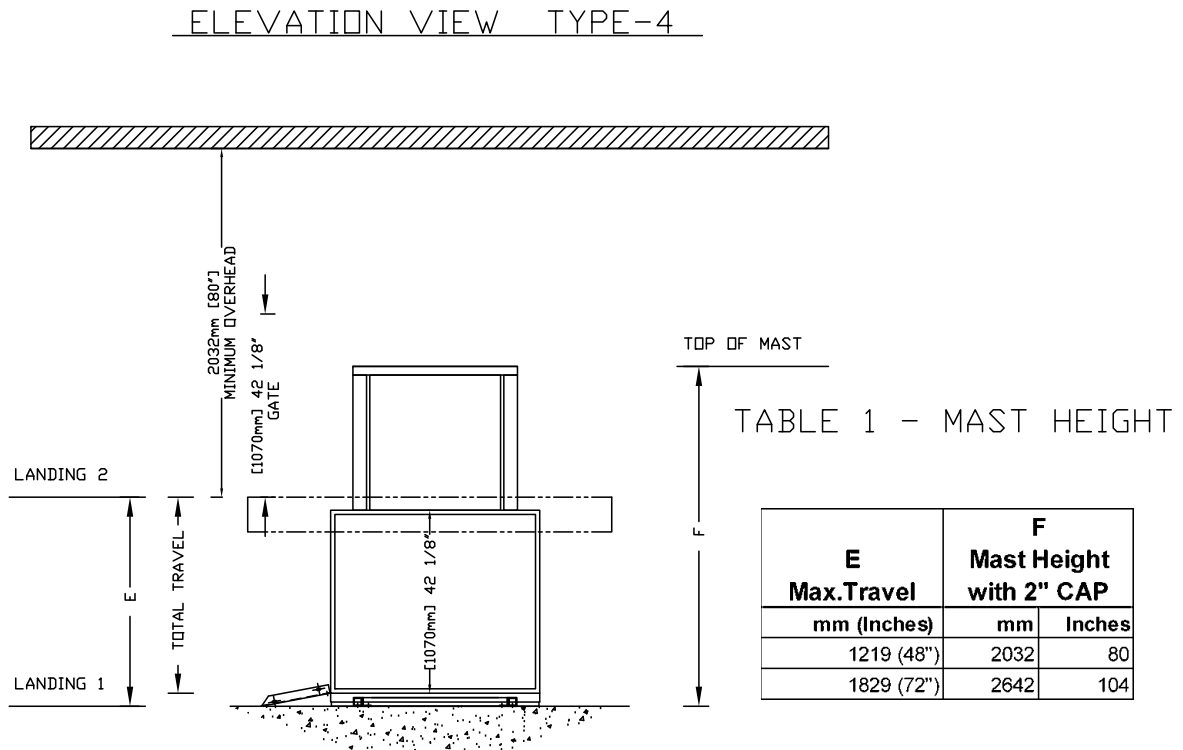

Figure 19: Elevation and plan view – type 4 without platform gate – 42" x 48", 42" x 54", 42" x 60"

ELEVATION VIEW TYPE-4

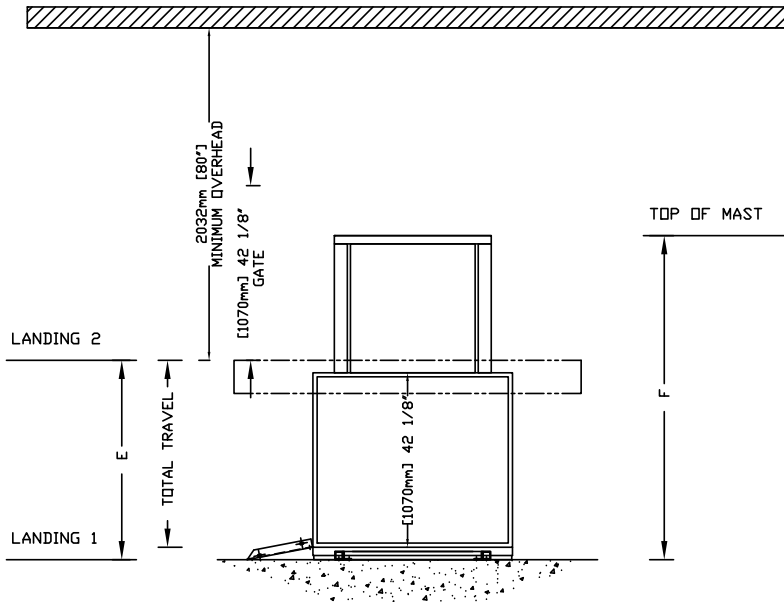
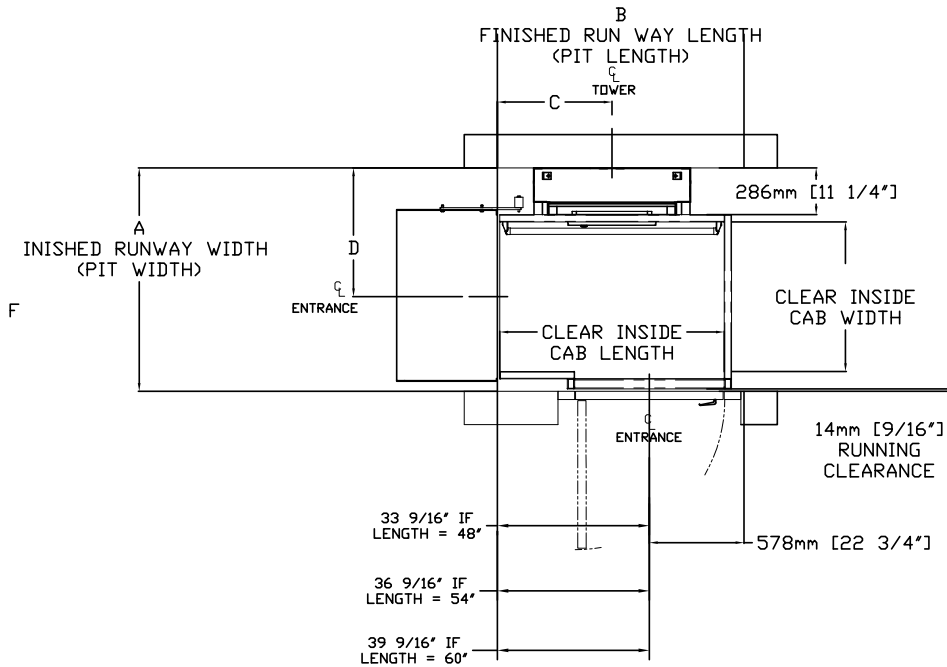

TABLE 1 – MAST HEIGHT

E Max.Travel	F Mast Height with 2" CAP	
	mm (Inches)	mm Inches
1219 (48")	2032	80
1829 (72")	2642	104

TOP VIEW TYPE-4



CLEAR INSIDE CAB WIDTH		CLEAR INSIDE CAB LENGTH		A FINISHED RUNWAY WIDTH		B FINISHED RUNWAY LENGTH		C TOWER CENTER LINE		D DOOR CENTER LINE (IN CASE OF 42" DOOR)	
mm	Inches	mm	Inches	mm	Inches	mm	Inches	mm	Inches	mm	Inches
1067	42	1219	48	1518	59 3/4	1354	53 5/16	624	24 9/16	864	34
1067	42	1372	54	1518	59 3/4	1507	59 5/16	700	27 9/16	864	34
1067	42	1524	60	1518	59 3/4	1659	65 5/16	776	30 9/16	864	34

Figure 20: Elevation and plan view – type 2 with platform gate – 36" x 54", 36" x 60"

ELEVATION VIEW TYPE-2

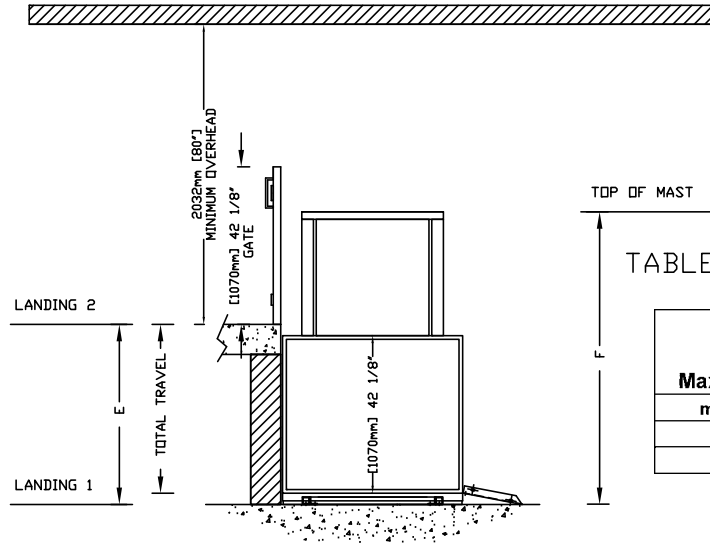

TABLE 1 - MAST HEIGHT

E Max.Travel	F Mast Height with 2" CAP	
	mm (Inches)	mm Inches
1219 (48")	2032	80
1829 (72")	2642	104

TOP VIEW TYPE-2

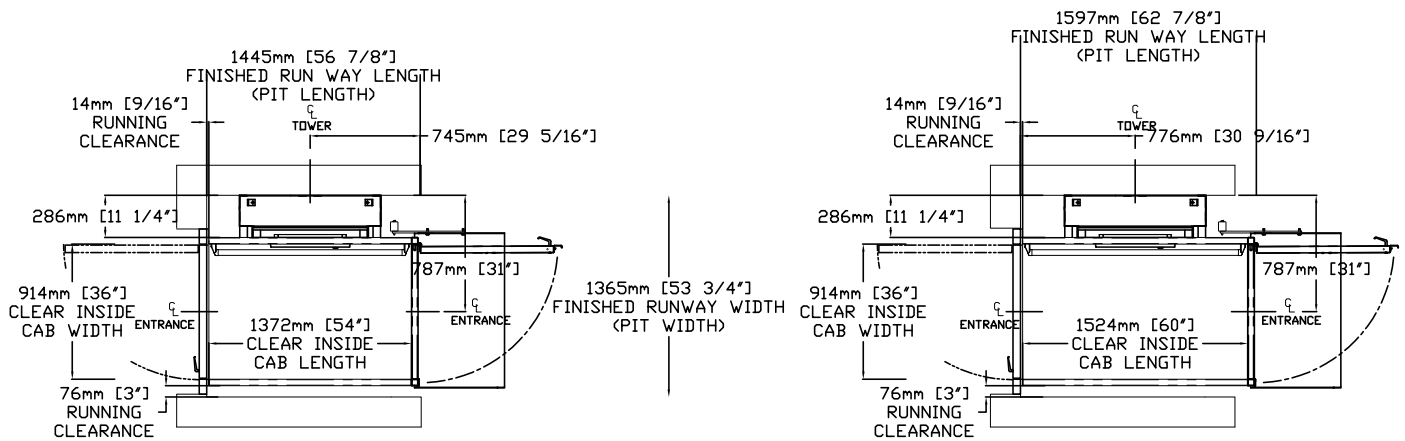

Figure 21: Elevation and plan view – type 2 with platform gate – 42" x 48", 42" x 54", 42" x 60"

ELEVATION VIEW TYPE-2

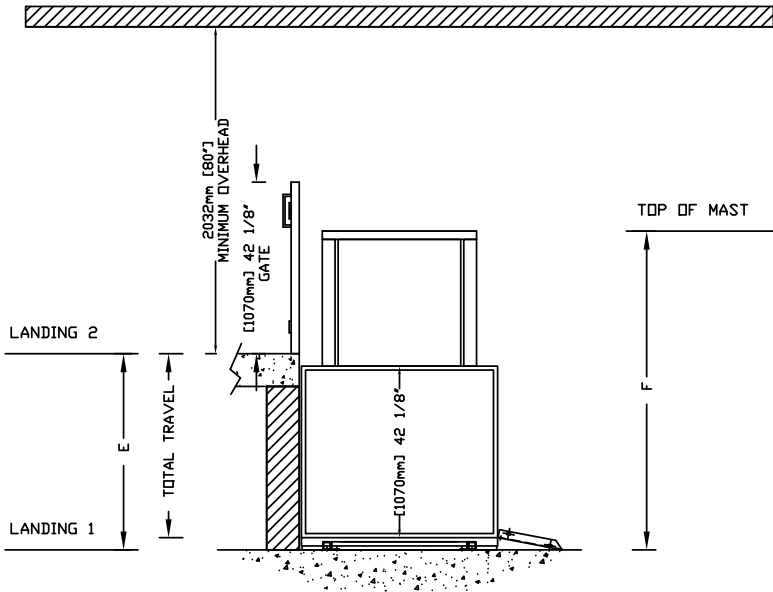

TABLE 1 - MAST HEIGHT

E Max.Travel	F Mast Height with 2" CAP	
	mm (Inches)	mm Inches
1219 (48")	2032	80
1829 (72")	2642	104

TOP VIEW TYPE-2

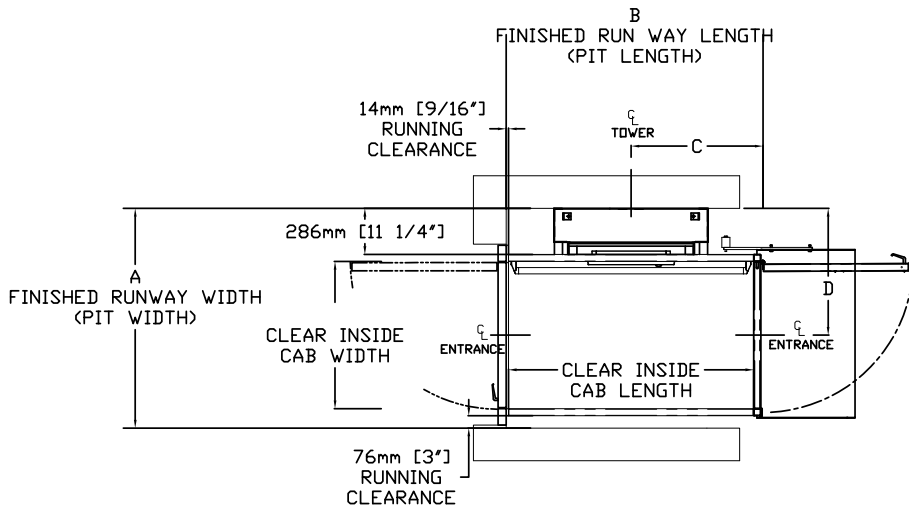

TABLE 2- HOISTWAY DIMENSION

CLEAR INSIDE CAB WIDTH		CLEAR INSIDE CAB LENGTH		A FINISHED RUNWAY WIDTH		B FINISHED RUNWAY LENGTH		C TOWER CENTER LINE		D DOOR CENTER LINE (IN CASE OF 42" DOOR)	
mm	Inches	mm	Inches	mm	Inches	mm	Inches	mm	Inches	mm	Inches
1067	42	1219	48	1518	59 3/4	1292	50 7/8	624	26 5/16	864	34
1067	42	1372	54	1518	59 3/4	1445	56 7/8	700	29 5/16	864	34
1067	42	1524	60	1518	59 3/4	1597	62 7/8	776	32 5/16	864	34

Figure 22: Elevation and plan view – type 3 with platform gate – 36" x 54", 36" x 60"

ELEVATION VIEW TYPE-3

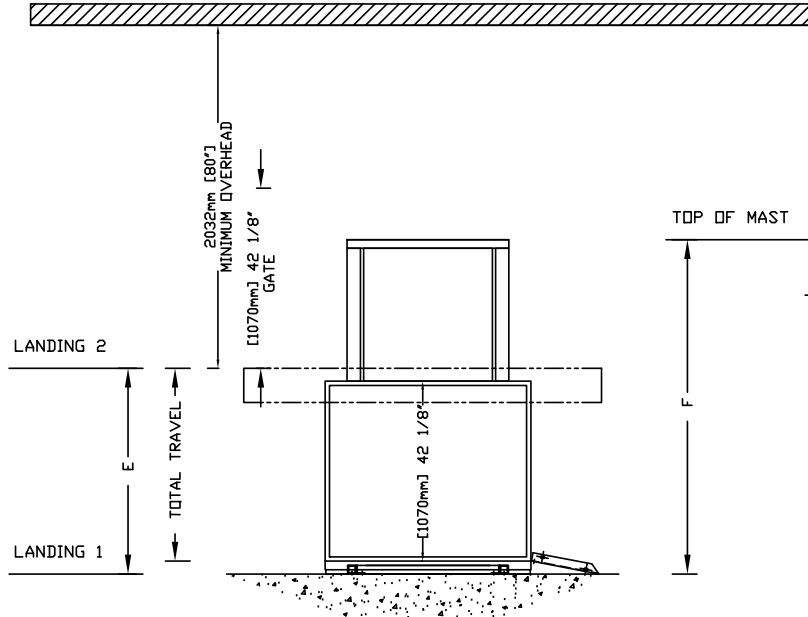

TABLE 1 - MAST HEIGHT

E Max.Travel	F Mast Height with 2" CAP	
	mm (Inches)	mm Inches
1219 (48")	2032	80
1829 (72")	2642	104

TOP VIEW TYPE-3

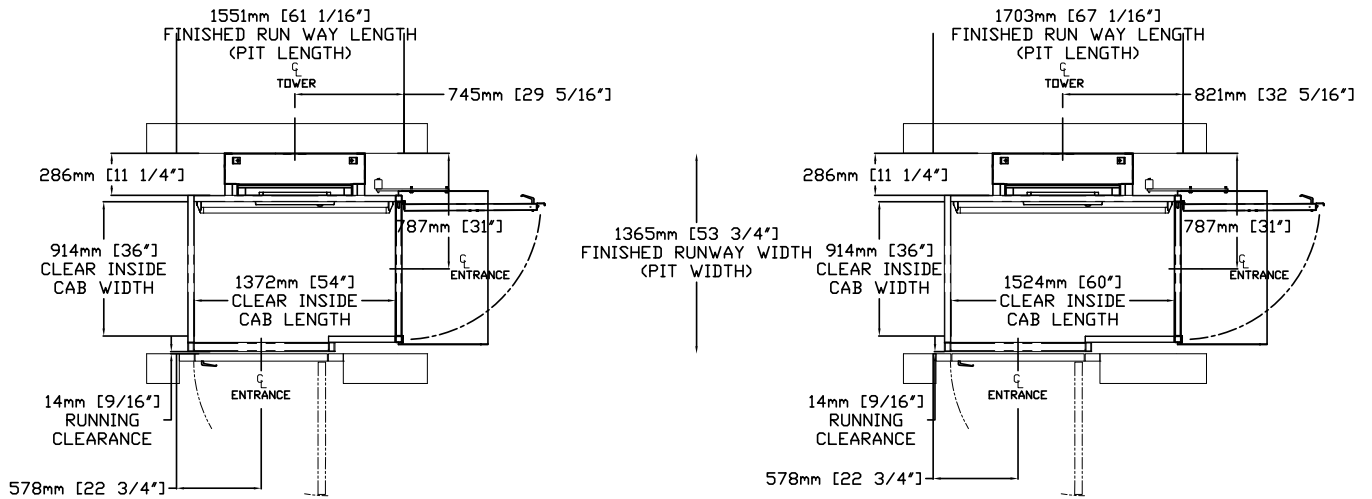

Figure 23: Elevation and plan view – type 3 (42" B side opening) with platform gate – 36" x 60"

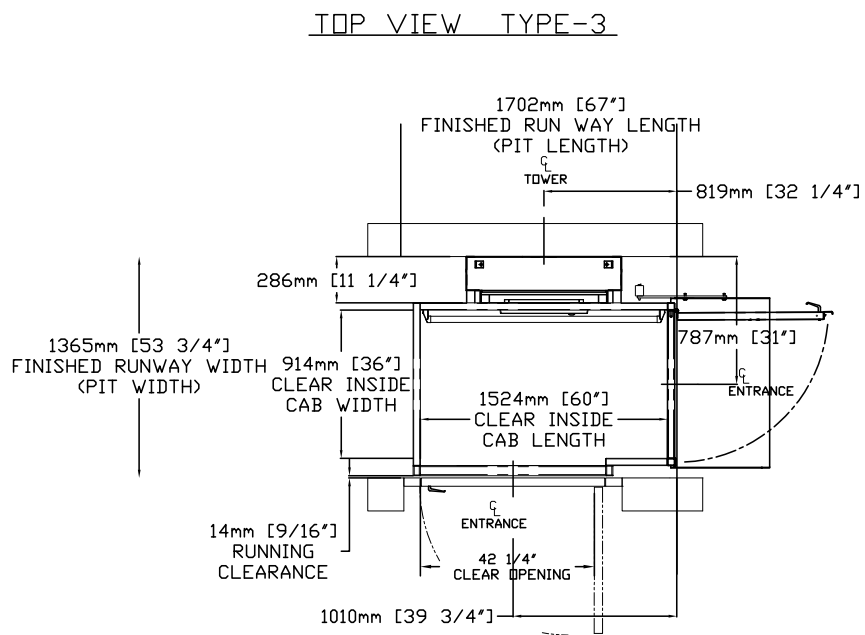
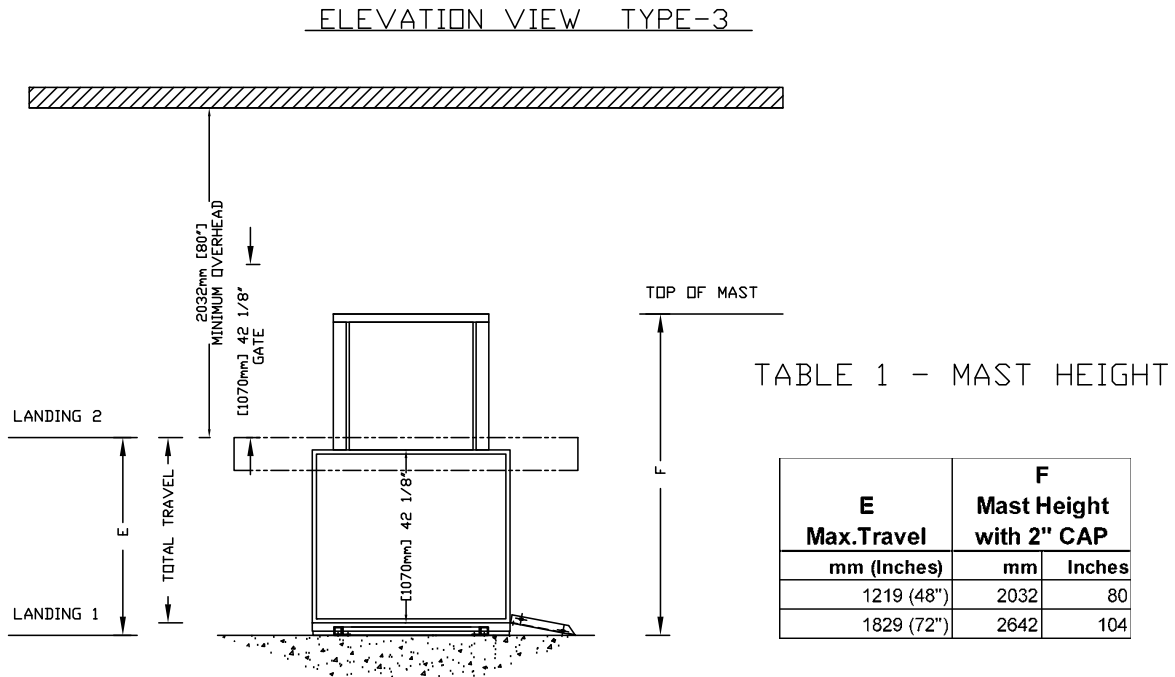

Figure 24: Elevation and plan view – type 3 (42" B side opening) with platform gate – 42" x 48", 42" x 54", 42" x 60"

ELEVATION VIEW TYPE-3

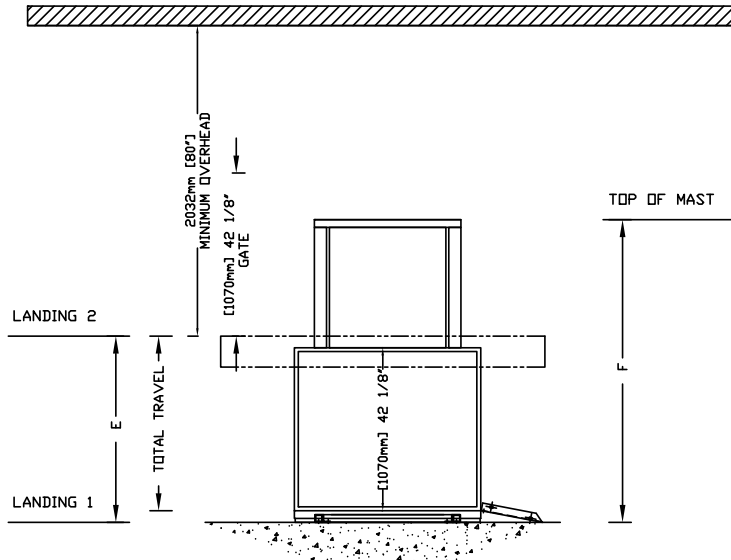

TABLE 1 - MAST HEIGHT

E Max.Travel	F Mast Height with 2" CAP	
	mm (Inches)	mm Inches
1219 (48")	2032	80
1829 (72")	2642	104

TOP VIEW TYPE-3

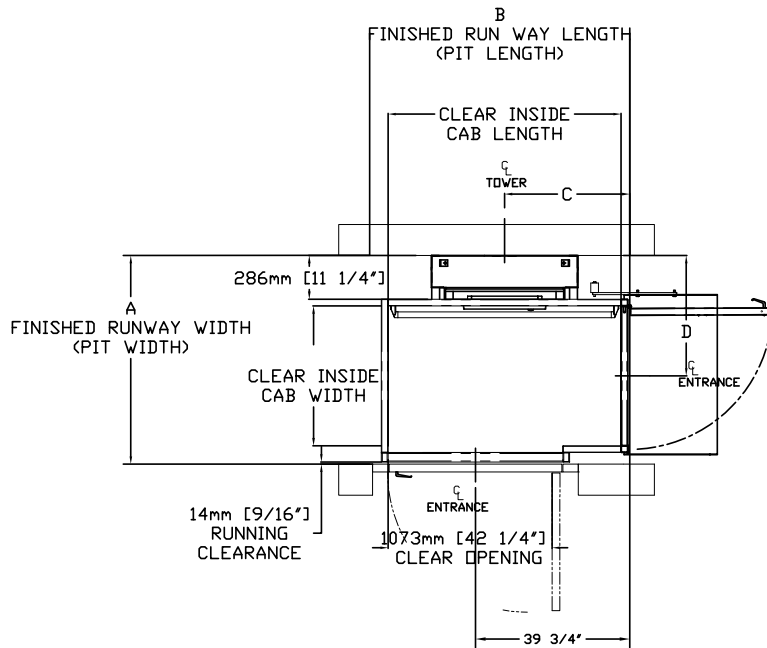

TABLE 2- HOISTWAY DIMENSION

CLEAR INSIDE CAB WIDTH		CLEAR INSIDE CAB LENGTH		A FINISHED RUNWAY WIDTH		B FINISHED RUNWAY LENGTH		C TOWER CENTER LINE		D DOOR CENTER LINE (IN CASE OF 42" DOOR)	
mm	Inches	mm	Inches	mm	Inches	mm	Inches	mm	Inches	mm	Inches
1067	42	1219	48	1518	59 3/4	1397	55	624	26 1/4	864	34
1067	42	1372	54	1518	59 3/4	1549	61	700	29 1/4	864	34
1067	42	1524	60	1518	59 3/4	1702	67	776	32 1/4	864	34

Figure 25: Elevation and plan view – type 4 with platform gate – 36" x 54", 36" x 60"

ELEVATION VIEW TYPE-4

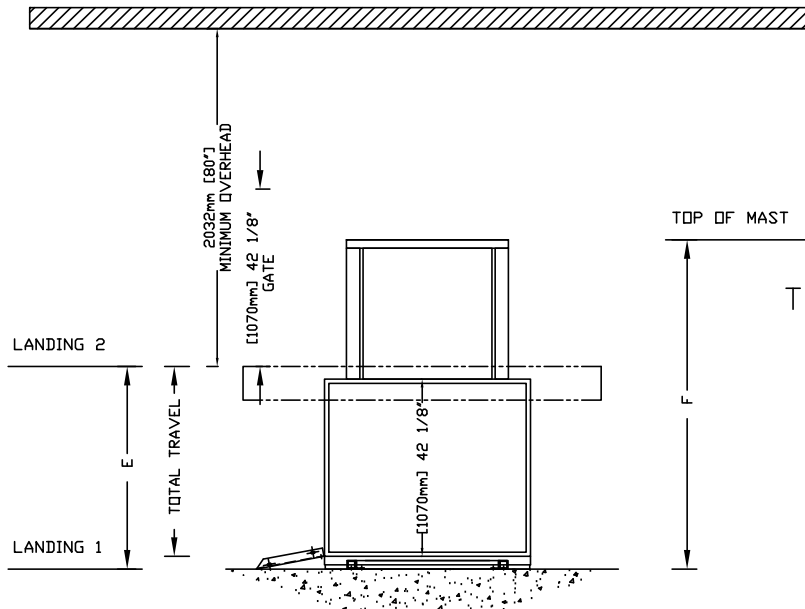

TABLE 1 - MAST HEIGHT

E Max.Travel	F Mast Height with 2" CAP	
	mm (Inches)	mm Inches
1219 (48")	2032	80
1829 (72")	2642	104

TOP VIEW TYPE-4

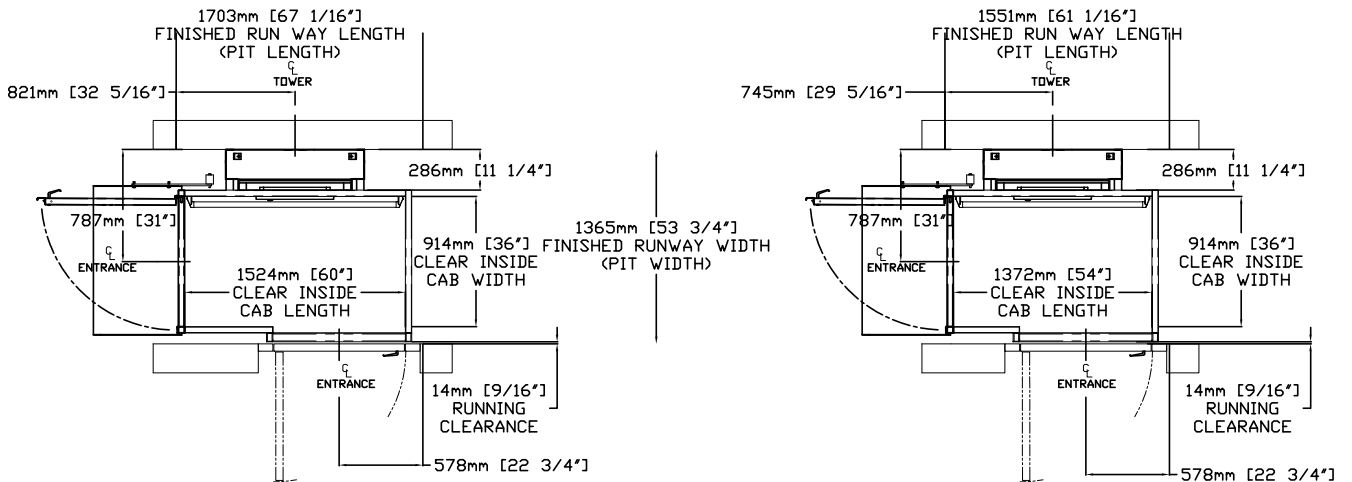

Figure 26: Elevation and plan view – type 4 with platform gate – 42" x 48", 42" x 54", 42" x 60"

ELEVATION VIEW TYPE-4

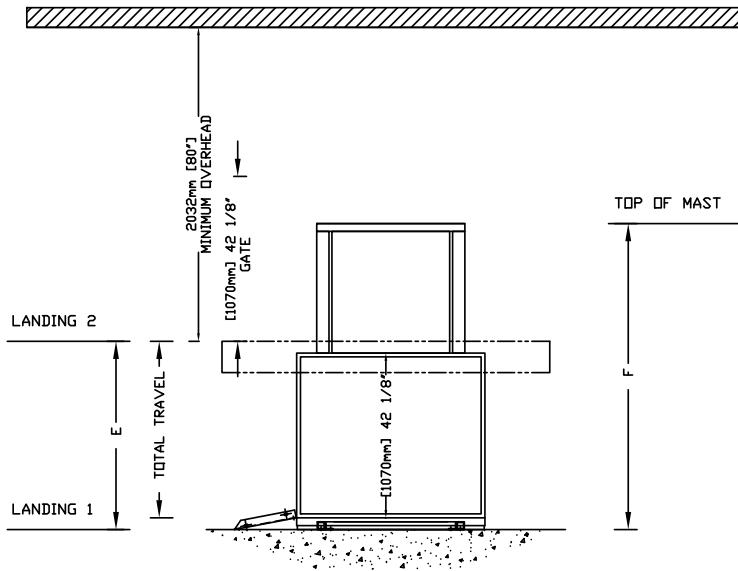

TABLE 1 – MAST HEIGHT

E Max.Travel	F Mast Height with 2" CAP	
	mm (Inches)	mm Inches
1219 (48")	2032	80
1829 (72")	2642	104

TOP VIEW TYPE-4

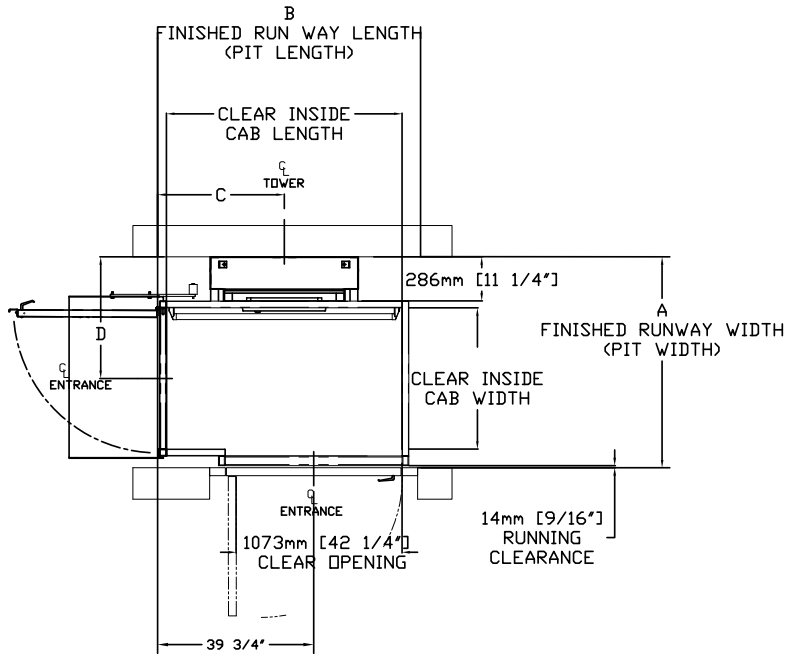

TABLE 2- HOISTWAY DIMENSION

CLEAR INSIDE CAB WIDTH		CLEAR INSIDE CAB LENGTH		A FINISHED RUNWAY WIDTH		B FINISHED RUNWAY LENGTH		C TOWER CENTER LINE		D DOOR CENTER LINE (IN CASE OF 42" DOOR)	
mm	Inches	mm	Inches	mm	Inches	mm	Inches	mm	Inches	mm	Inches
1067	42	1219	48	1518	59 3/4	1397	55	624	26 1/4	864	34
1067	42	1372	54	1518	59 3/4	1549	61	700	29 1/4	864	34
1067	42	1524	60	1518	59 3/4	1702	67	776	32 1/4	864	34

Figure 27: Elevation and plan view – type 4 (42" B side opening) with platform gate – 36" x 60"

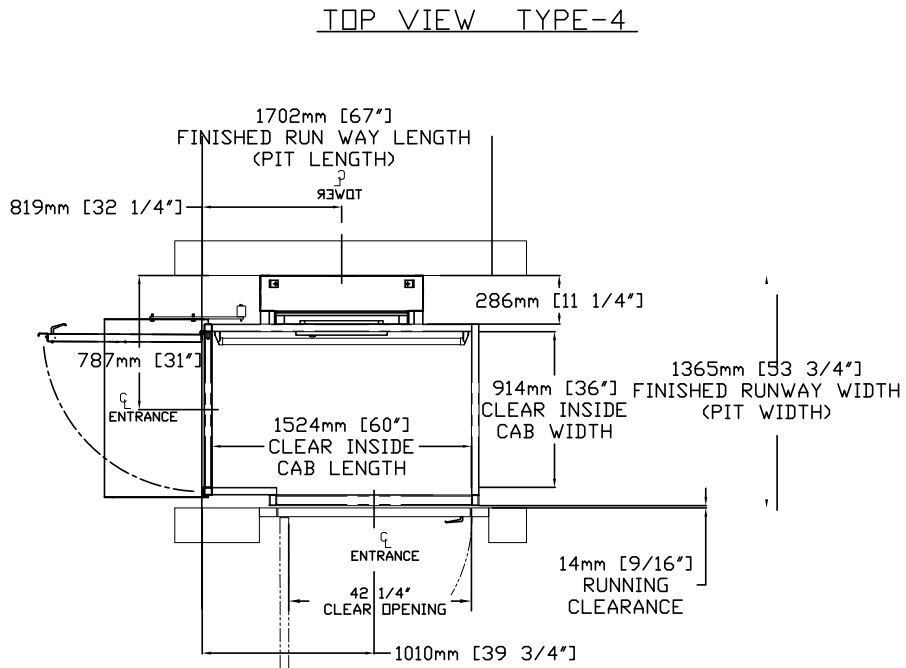
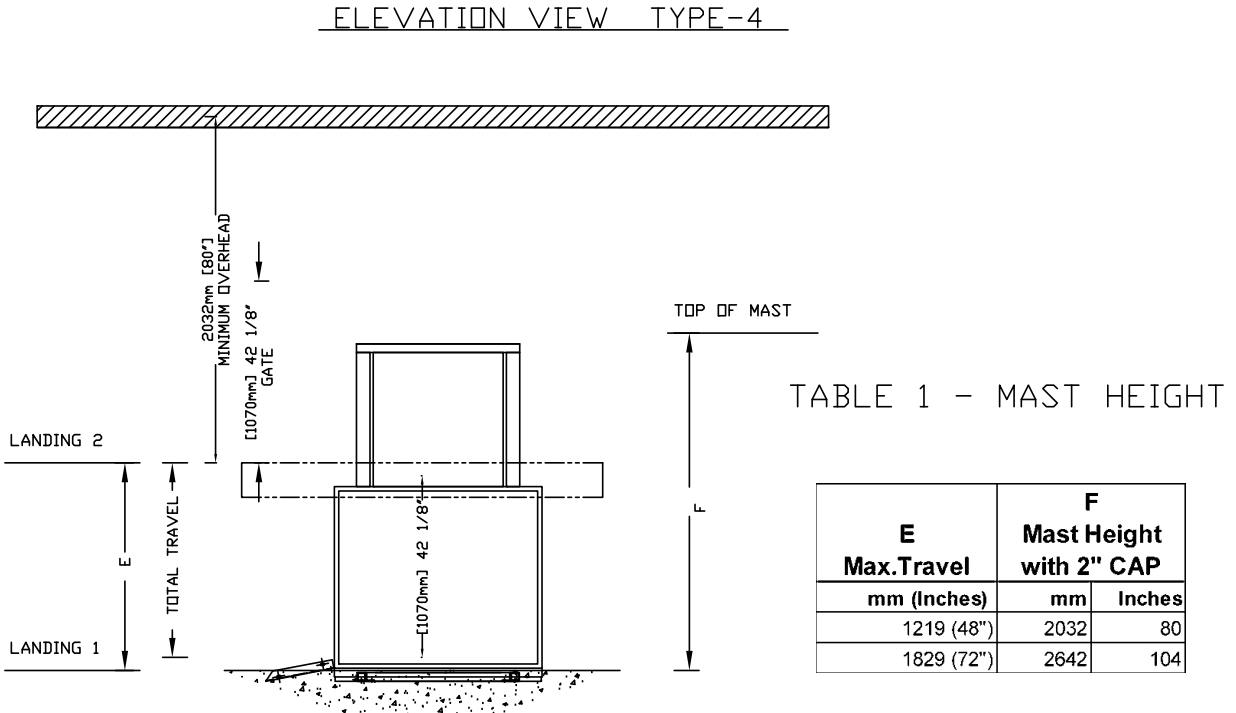

Figure 28: Elevation and plan view – type 2 enclosure – 36" x 48", 36" x 54", 36" x 60"

ELEVATION VIEW TYPE-2

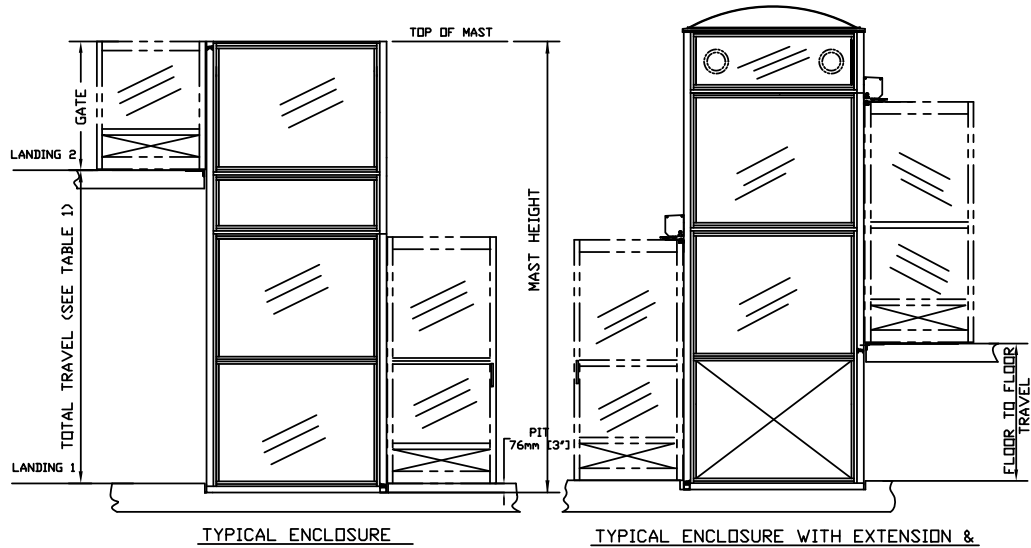

TABLE 1- MAST HEIGHT

TRAVEL	TOWER HEIGHT		MIN ENCLOSURE HEIGHT	
	mm (Inches)	mm Inches	mm	Inches
1219 (48")	2032	80	2286	90
1829 (72")	2642	104	2896	114

TOP VIEW TYPE-2

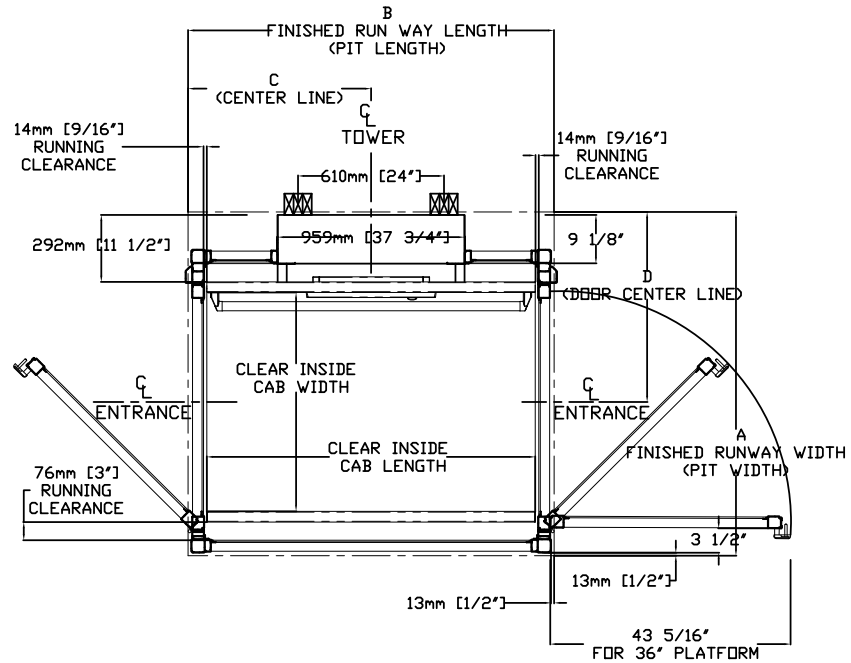

TABLE 2 - ENCLOSURE DIMENSION

CLEAR INSIDE CAB WIDTH		CLEAR INSIDE CAB LENGTH		A FINISHED RUNWAY WIDTH		B FINISHED RUNWAY LENGTH		C TOWER CENTER LINE		D DOOR CENTER LINE (IN CASE OF 36" DOOR)	
mm	Inches	mm	Inches	mm	Inches	mm	Inches	mm	Inches	mm	Inches
914	36	1219	48	1449	57 1/16	1376	54 3/16	687	27 1/16	806	31 3/4
914	36	1372	54	1449	57 1/16	1529	60 3/16	764	30 1/16	806	31 3/4
914	36	1524	60	1449	57 1/16	1681	66 3/16	840	33 1/16	806	31 3/4

Figure 29: Elevation and plan view – type 2 enclosure – 42" x 48", 42" x 54", 42" x 60"

ELEVATION VIEW TYPE-2

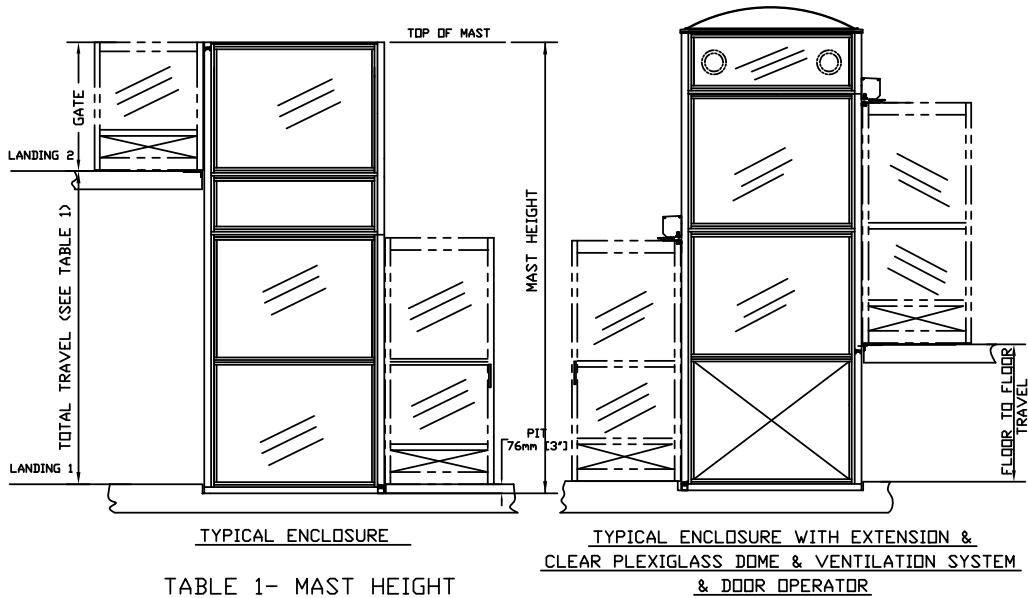

TABLE 1- MAST HEIGHT

TRAVEL		TOWER HEIGHT		MIN ENCLOSURE HEIGHT	
mm	Inches	mm	Inches	mm	Inches
1219	48"	2032	80	2286	90
1829	72"	2642	104	2896	114

TOP VIEW TYPE-2

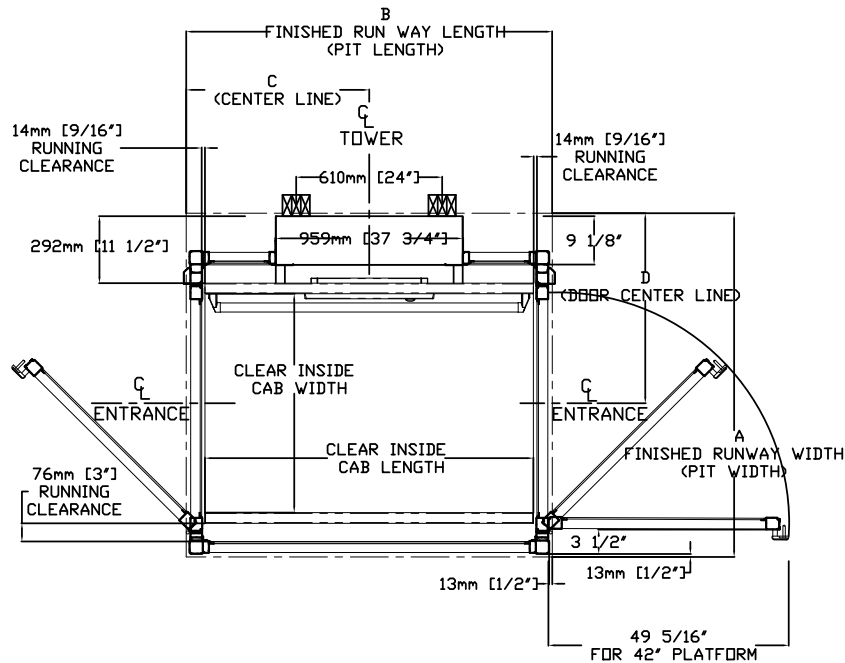

TABLE 2 - ENCLOSURE DIMENSION

CLEAR INSIDE CAB WIDTH		CLEAR INSIDE CAB LENGTH		A FINISHED RUNWAY WIDTH		B FINISHED RUNWAY LENGTH		C TOWER CENTER LINE		D DOOR CENTER LINE (IN CASE OF 36" DOOR)	
mm	Inches	mm	Inches	mm	Inches	mm	Inches	mm	Inches	mm	Inches
1067	42	1219	48	1589	62 9/16	1376	54 3/16	687	27 1/16	883	34 3/4
1067	42	1372	54	1589	62 9/16	1529	60 3/16	764	30 1/16	883	34 3/4
1067	42	1524	60	1589	62 9/16	1681	66 3/16	840	33 1/16	883	34 3/4

Figure 30: Elevation and plan view – type 3 enclosure – 36" x 48", 36" x 54", 36" x 60"

ELEVATION VIEW TYPE-3

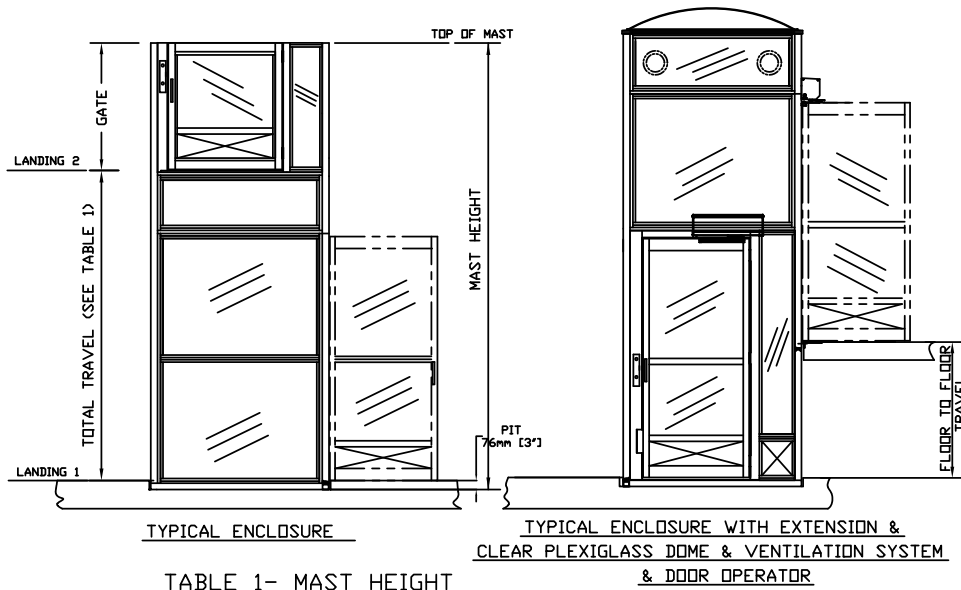

TABLE 1- MAST HEIGHT

TRAVEL	TOWER HEIGHT		MIN ENCLOSURE HEIGHT	
	mm	Inches	mm	Inches
1219 (48")	2032	80	2286	90
1829 (72")	2642	104	2896	114

TOP VIEW TYPE-3

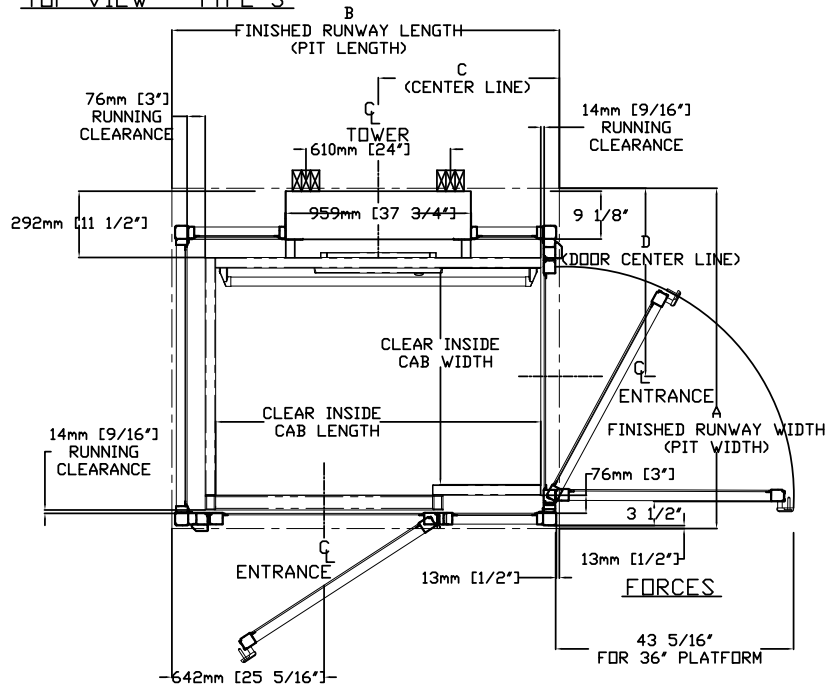

TABLE 2 - ENCLOSURE DIMENSION

CLEAR INSIDE CAB WIDTH		CLEAR INSIDE CAB LENGTH		A		B		C		D	
mm	Inches	mm	Inches	mm	Inches	mm	Inches	mm	Inches	mm	Inches
914	36	1219	48	1449	57 1/16	1483	58 3/8	687	27 1/16	806	31 3/4
914	36	1372	54	1449	57 1/16	1635	64 3/8	764	30 1/16	806	31 3/4
914	36	1524	60	1449	57 1/16	1788	70 3/8	840	33 1/16	806	31 3/4

Figure 31: Elevation and plan view – type 3 enclosure – 42" x 48", 42" x 54", 42" x 60"

ELEVATION VIEW TYPE-3

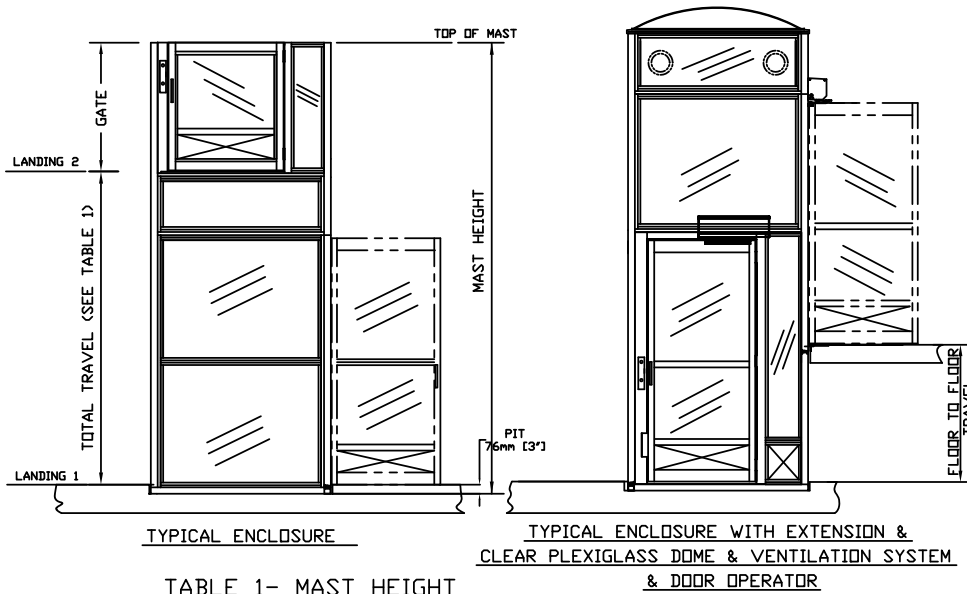

TABLE 1- MAST HEIGHT

TRAVEL mm (Inches)	TOWER HEIGHT		MIN ENCLOSURE HEIGHT	
	mm	Inches	mm	Inches
1219 (48")	2032	80	2286	90
1829 (72")	2642	104	2896	114

TOP VIEW TYPE-3

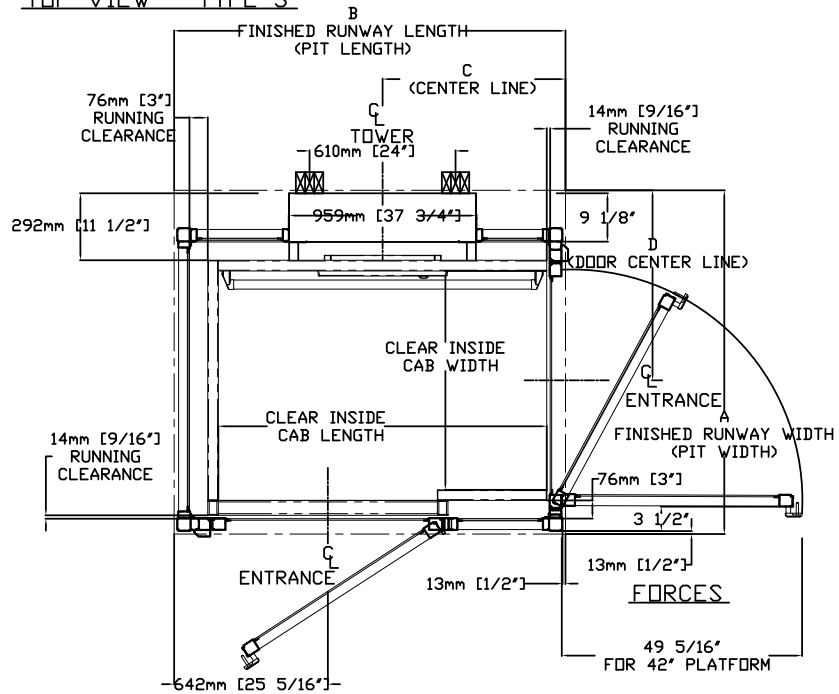

TABLE 2 - ENCLOSURE DIMENSION

CLEAR INSIDE CAB WIDTH		CLEAR INSIDE CAB LENGTH		A FINISHED RUNWAY WIDTH		B FINISHED RUNWAY LENGTH		C TOWER CENTER LINE		D DOOR CENTER LINE (IN CASE OF 36" DOOR)	
mm	Inches	mm	Inches	mm	Inches	mm	Inches	mm	Inches	mm	Inches
1067	42	1219	48	1602	63 1/16	1483	58 3/8	687	27 1/16	883	34 3/4
1067	42	1372	54	1602	63 1/16	1635	64 3/8	764	30 1/16	883	34 3/4
1067	42	1524	60	1602	63 1/16	1788	70 3/8	840	33 1/16	883	34 3/4

Figure 32: Elevation and plan view – type 4 enclosure – 36" x 48", 36" x 54", 36" x 60"

ELEVATION VIEW TYPE-4

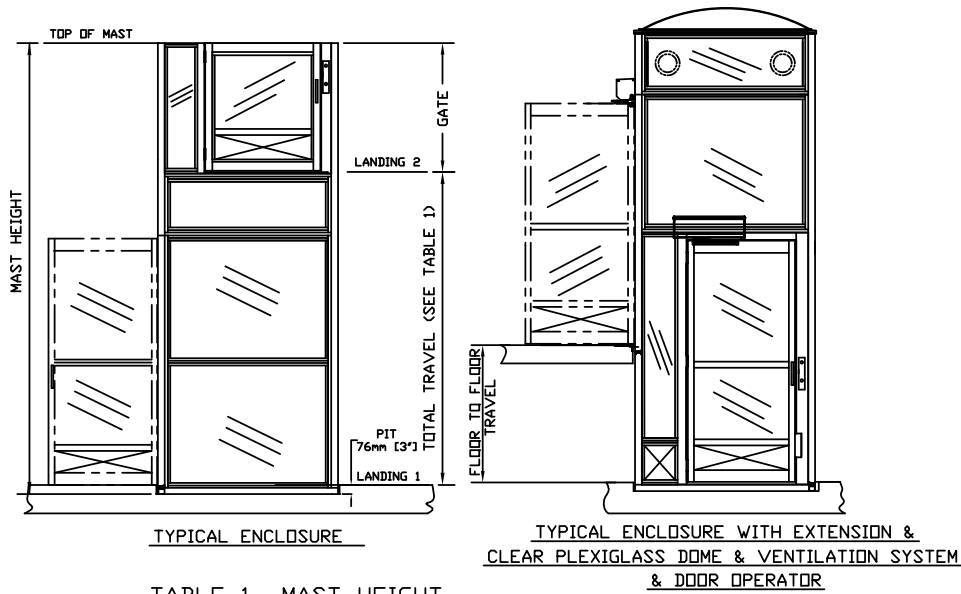

TABLE 1- MAST HEIGHT

TRAVEL mm (Inches)	TOWER HEIGHT		MIN ENCLOSURE HEIGHT	
	mm	Inches	mm	Inches
1219 (48")	2032	80	2286	90
1829 (72")	2642	104	2896	114

TOP VIEW TYPE-4

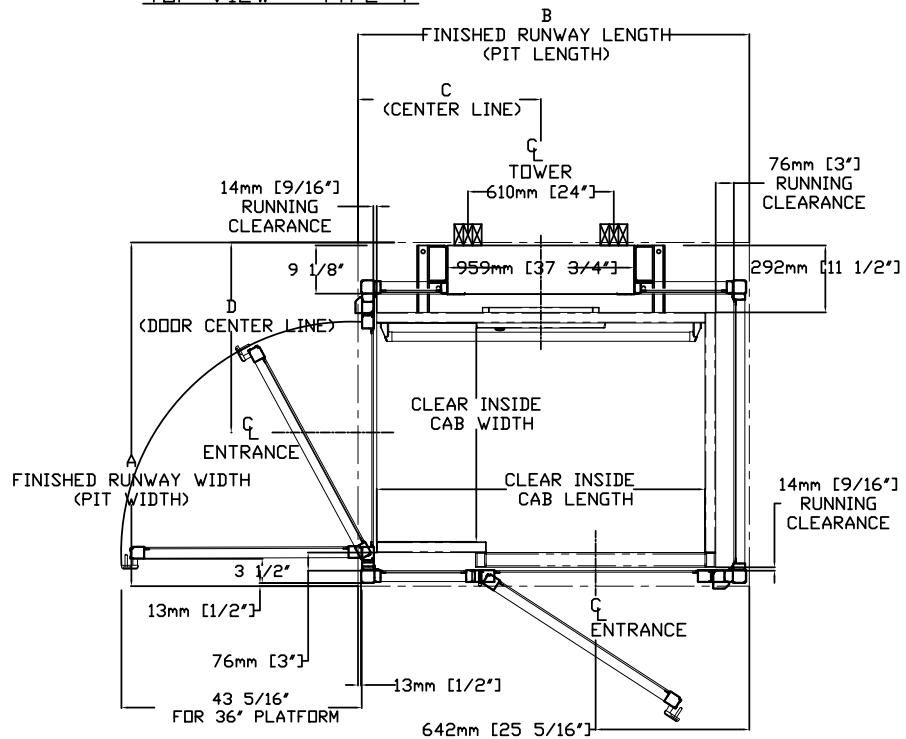

TABLE 2 - ENCLOSURE DIMENSION

CLEAR INSIDE CAB WIDTH		CLEAR INSIDE CAB LENGTH		A FINISHED RUNWAY WIDTH		B FINISHED RUNWAY LENGTH		C TOWER CENTER LINE		D DOOR CENTER LINE (IN CASE OF 36" DOOR)	
mm	Inches	mm	Inches	mm	Inches	mm	Inches	mm	Inches	mm	Inches
914	36	1219	48	1449	57 1/16	1483	58 3/8	687	27 1/16	806	31 3/4
914	36	1372	54	1449	57 1/16	1635	64 3/8	764	30 1/16	806	31 3/4
914	36	1524	60	1449	57 1/16	1788	70 3/8	840	33 1/16	806	31 3/4

Figure 33: Elevation and plan view – type 4 enclosure – 42" x 48", 42" x 54", 42" x 60"

ELEVATION VIEW TYPE-4

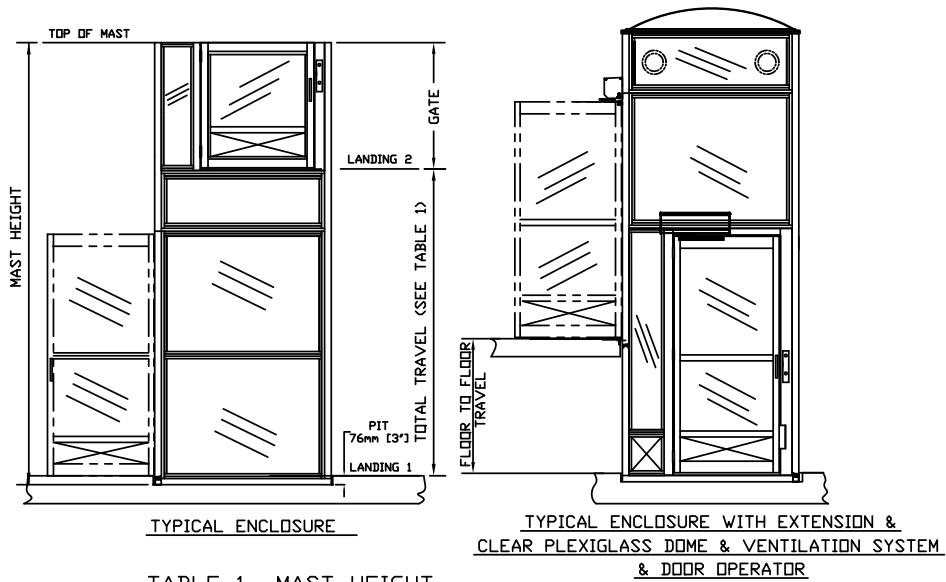

TABLE 1- MAST HEIGHT

TRAVEL	TOWER HEIGHT		MIN ENCLOSURE HEIGHT	
mm (Inches)	mm	Inches	mm	Inches
1219 (48")	2032	80	2286	90
1829 (72")	2642	104	2896	114

TOP VIEW TYPE-4

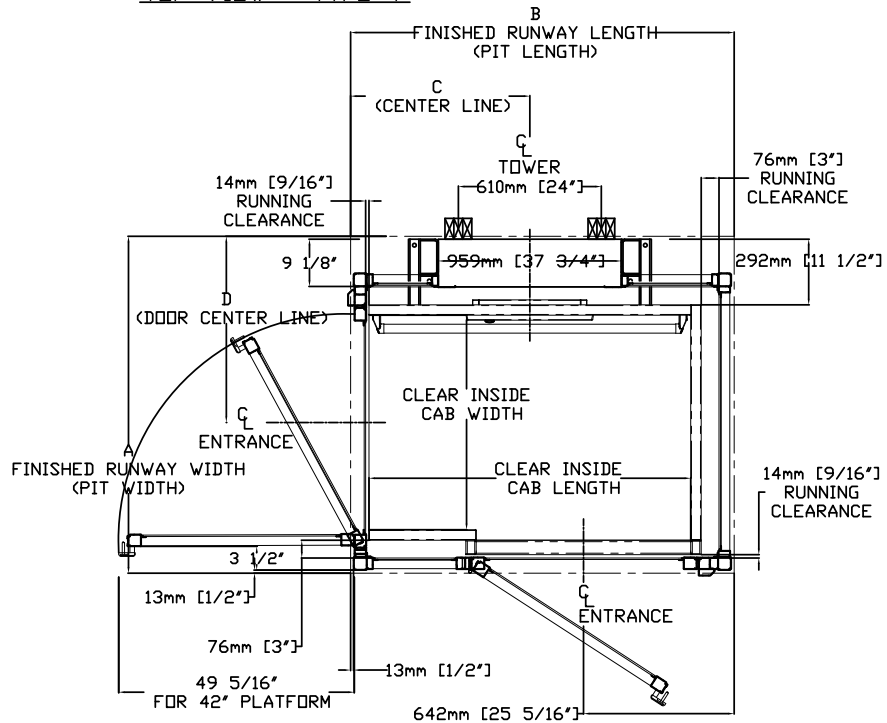
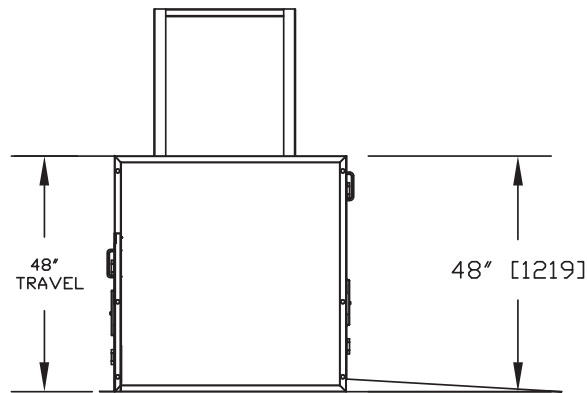
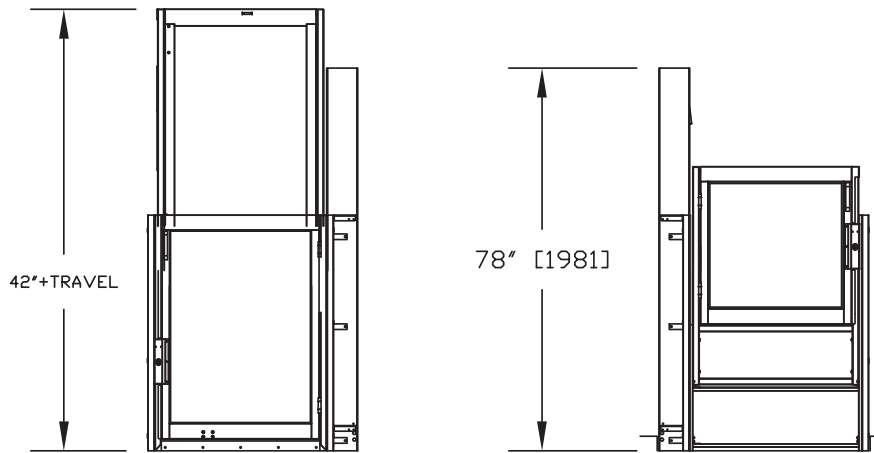

TABLE 2 - ENCLOSURE DIMENSION

CLEAR INSIDE CAB WIDTH		CLEAR INSIDE CAB LENGTH		A FINISHED RUNWAY WIDTH		B FINISHED RUNWAY LENGTH		C TOWER CENTER LINE		D DOOR CENTER LINE (IN CASE OF 36" DOOR)	
mm	Inches	mm	Inches	mm	Inches	mm	Inches	mm	Inches	mm	Inches
1067	42	1219	48	1602	63 1/16	1483	58 3/8	687	27 1/16	883	34 3/4
1067	42	1372	54	1602	63 1/16	1635	64 3/8	764	30 1/16	883	34 3/4
1067	42	1524	60	1602	63 1/16	1788	70 3/8	840	33 1/16	883	34 3/4

Figure 34: Elevation and plan view – type 2 with 3 gates (RH) – 36" x 54"



TOP VIEW TYPE-2

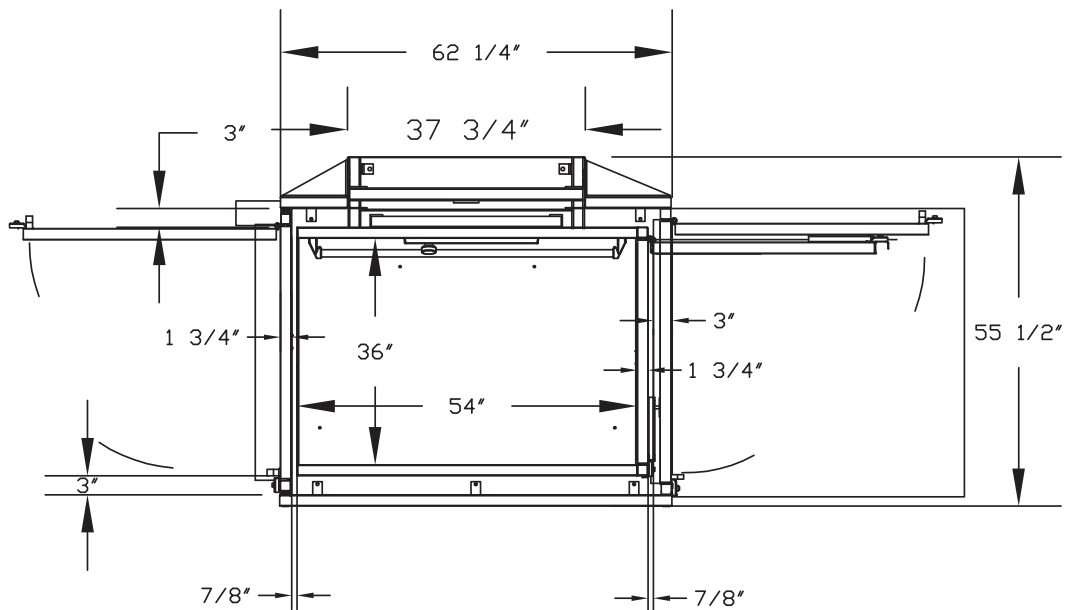
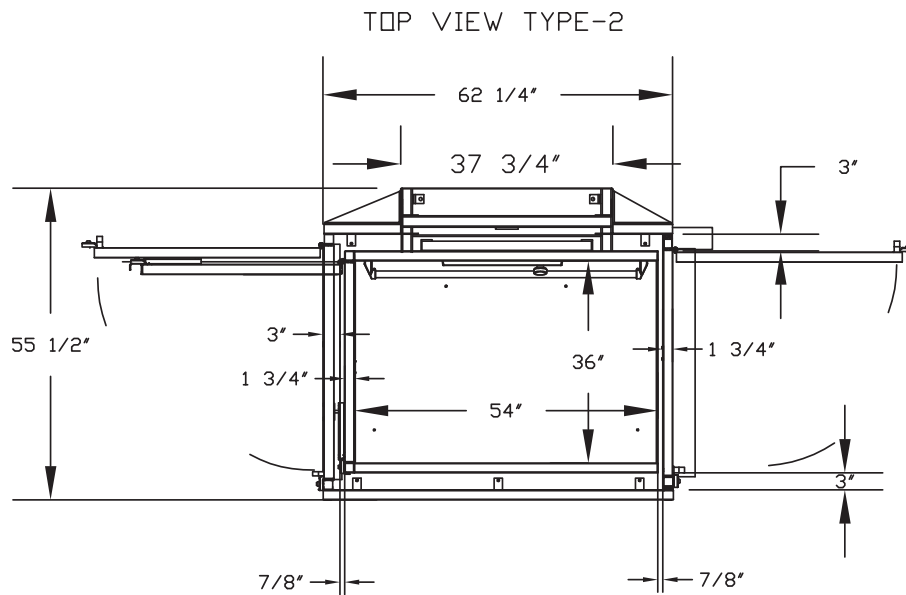
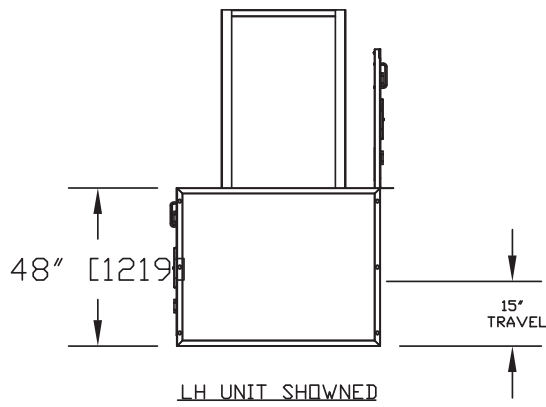
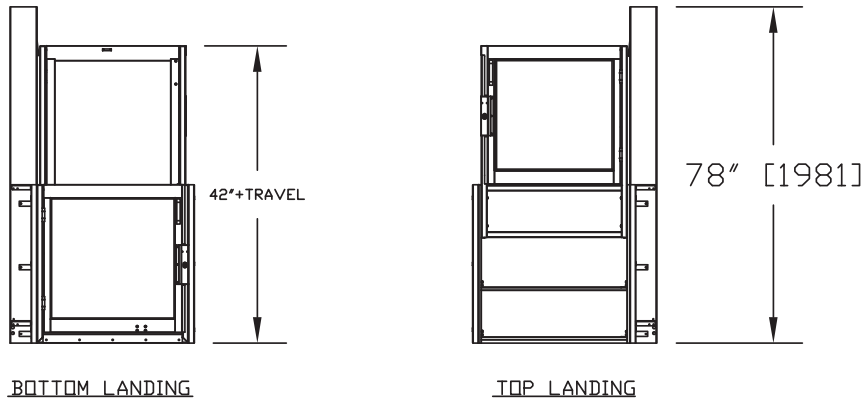

Figure 35: Elevation and plan view – type 2 with 3 gates (LH) – 36" x 54"



TYPICAL PLAN

Figure 36: 42" x 36" Auto left-hand gate

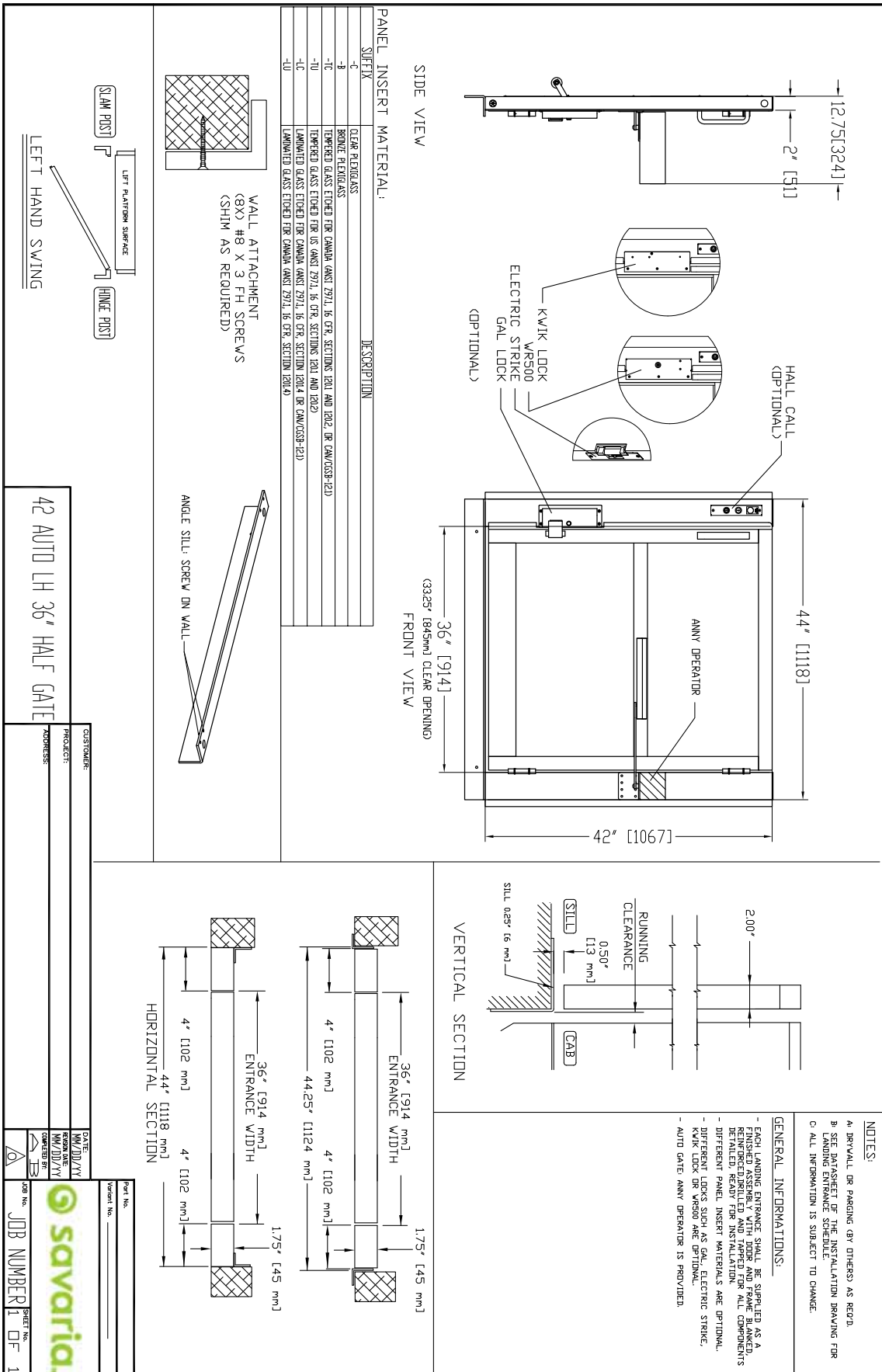

Figure 37: 42" x 36" Manual left-hand gate

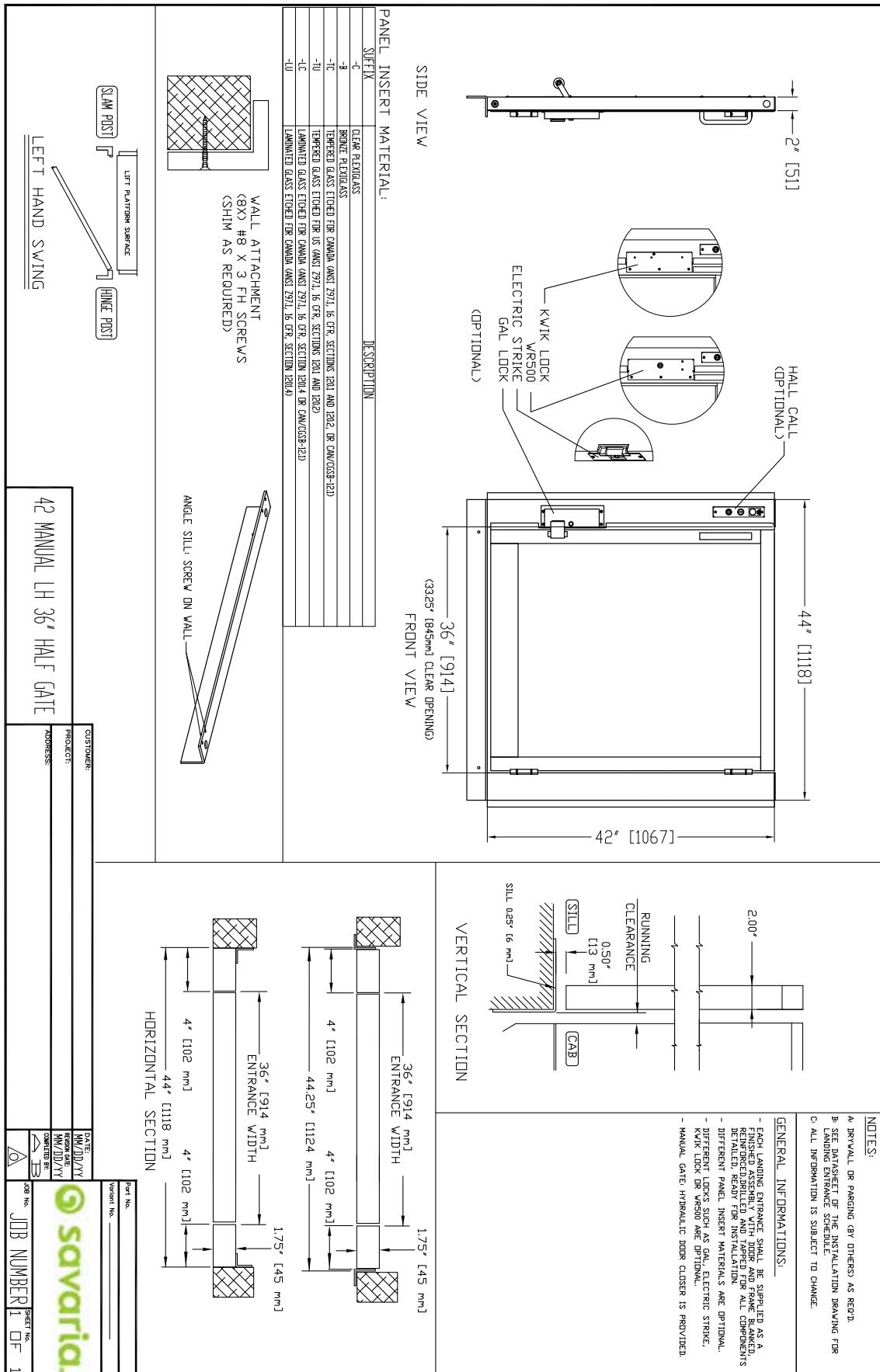
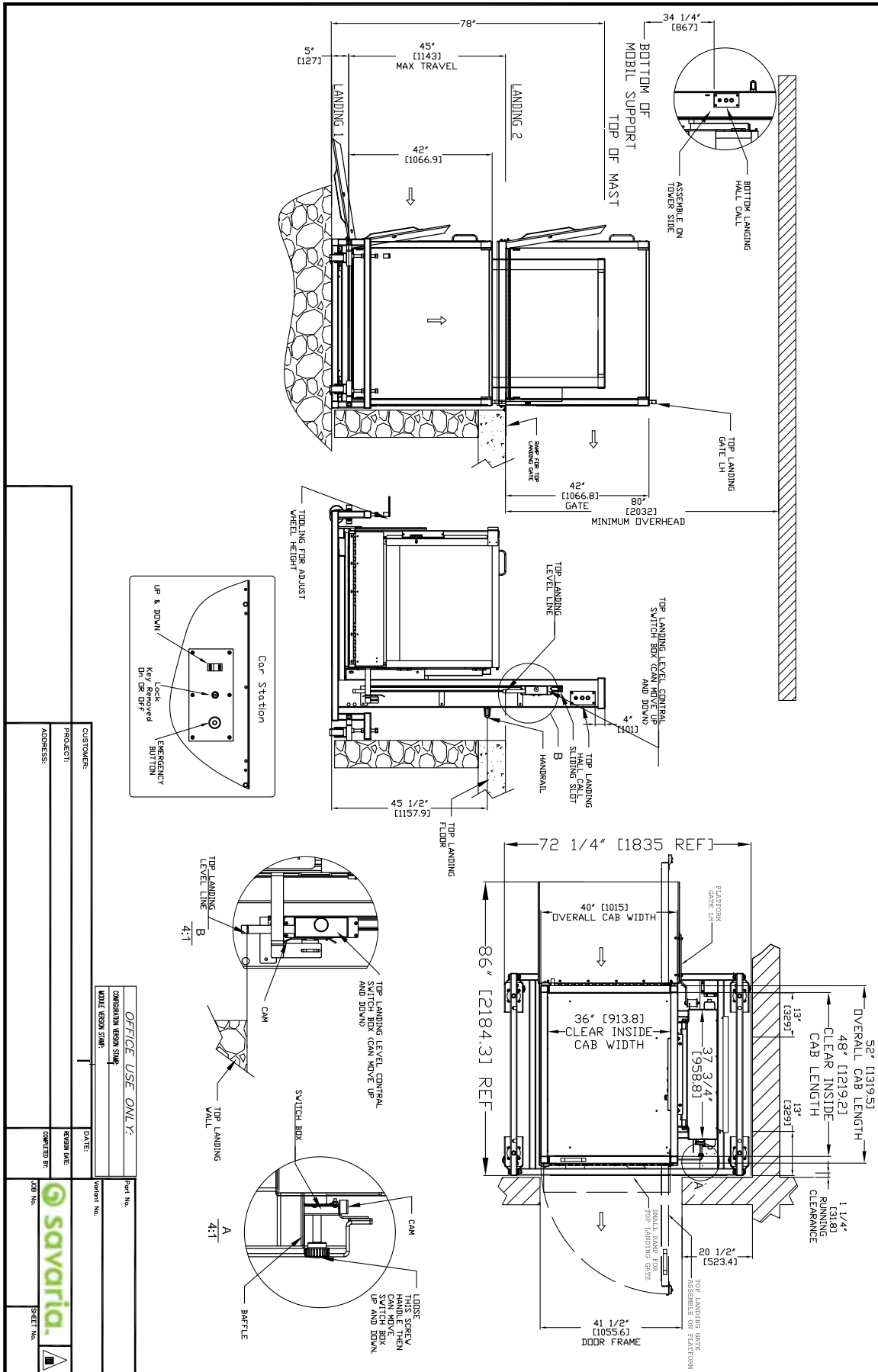

Figure 39: Mobile Multilift LH



CUSTOMER:	PROJECT:	REGION A/E:	DATE:
ADDRESS:		OPERATED BY:	
		JOB NO.:	
		SHEET NO.:	

OFFICE USE ONLY:	Part No.
CONVERSION REGION SIGNATURE:	Variant No.
WRITE REGION SIGNATURE:	



Provisions by others

PROVISIONS BY OTHERS

GENERAL

HOISTWAY - THE HOISTWAY MUST BE DESIGNED AND BUILT IN ACCORDANCE WITH 'SAFETY STANDARD FOR PLATFORM LIFTS AND STAIRWAY CHAIRLIFTS' OR 'SAFETY CODE FOR ELEVATORS AND ESCALATORS' AND ALL STATE/PROVINCIALS AND LOCAL CODES.

PLUMB RUNWAY- DUE TO CLOSE RUNNING CLEARANCES OWNER/AGENT MUST ENSURE THAT HOISTWAY AND PIT (WHERE PROVIDED) ARE LEVEL, PLUMB ($\pm 1/8"$ (3 mm)) AND SQUARE AND ARE IN ACCORDANCE WITH THE DIMENSIONS ON THESE DRAWINGS.

MINIMUM OVERHEAD CLEARANCE- OWNER/AGENT MUST ENSURE MINIMUM OVERHEAD CLEARANCE IS IN COMPLIANCE WITH CODES.

CONSTRUCTION SITE- OWNER/AGENT TO PROVIDE ALL MASONRY, CARPENTRY AND DRYWALL WORK AS REQUIRED AND SHALL PATCH AND MAKE GOOD (INCLUDING FINISH PAINTING) ALL AREAS WHERE WALLS/FLOORS MAY REQUIRE TO BE CUT, DRILLED OR ALTERED IN ANY WAY TO PERMIT THE PROPER INSTALLATION OF THE LIFT.

DIMENSIONS- CONTRACTOR/CUSTOMER TO VERIFY ALL DIMENSIONS AND REPORT ANY DISCREPANCIES TO OUR OFFICE IMMEDIATELY.

STRUCTURAL

FLOOR/SUPPORT WALL LOADS-STRUCTURAL ENGINEER TO ASSURE THAT BUILDING AND SHAFT WILL SAFELY SUPPORT ALL LOADS IMPOSED BY THE LIFT EQUIPMENT. REFER TO THE LOAD DIAGRAM ON THIS DRAWING.

MAST TO BE SECURELY FASTENED- WHERE REQUIRED THE MAST MUST BE SECURELY FASTENED TO THE STRUCTURAL SUPPORT WALL. REFER TO WALL / FLOOR SUPPORT LOAD DIAGRAM AND WALL LAG DIMENSIONS ON THIS DRAWING.

WHERE DOORS ARE REQUIRED- SUITABLE LINTELS MUST BE PROVIDED BY OWNER/AGENT. DOOR FRAMES ARE NOT DESIGNED TO SUPPORT OVERHEAD WALL LOADS.

ELECTRICAL

GENERAL- ELECTRICAL EQUIPMENT AND WIRING TO COMPLY WITH SECTION 38 OF CSA C22.1 (CANADA) OR SECTION 620 OF NEC ANSI/NFPA 70 (USA).

POWER SUPPLY-120VAC, 20A, 60HZ, 1PH CIRCUIT THROUGH A FUSE DISCONNECT WITH AUXILIARY CONTACT ON MAIN POWER SUPPLY. PROVIDE TWO 18 AWG CONDUCTORS BETWEEN CONTACT AND CONTROLLER.

LIGHTING-LIGHTING OF 100 LX MIN. AT PLATFORM AND LANDINGS. LIGHTING WITH SWITCH AND ELECTRICAL GFCI OUTLET IN HOISTWAY PIT.

ADDITIONAL BRANCH CIRCUIT- BRANCH CIRCUIT WITH DISCONNECT FOR DOOR OPERATORS (IF EQUIPPED) (120VAC, 15A, 60HZ, 1PH) BRANCH CIRCUIT WITH DISCONNECT FOR VENTILATION SYSTEM (IF EQUIPPED) (120VAC, 15A, 60HZ, 1PH)

ENTRANCES

UPPER LANDING GATES- WHERE REQUIRED, SMOOTH SOLID BARRIERS ARE TO BE SUPPLIED AND INSTALLED ON BOTH SIDES OF ENTRANCE AT UPPER LEVEL AND MUST BE A MINIMUM OF 42" (1067 mm) HIGH. ENTRANCE ASSEMBLY MUST BE IN PLACE PRIOR TO THIS PROVISION.

FASCIA PANEL BELOW UPPER LEVEL ENTRANCE- WHERE REQUIRED, FASCIA PANEL MUST BE FASTENED TO A SOLID WALL AND BE PERPENDICULAR TO THE FLOOR AND WALLS. HOISTWAY FASCIA IS NOT SELF-SUPPORTING FOR LONG, CONTINUOUS RUNS VOID OF ENTRANCES. ADEQUATE SUPPORT FOR THE FASCIA MUST BE PROVIDED.

ENTRANCE ASSEMBLIES- ENTRANCE ASSEMBLIES MUST BE ADJUSTED TO ALIGN WITH PLATFORM AND INTERLOCK EQUIPMENT. OTHERS TO ALLOW AN ADEQUATE ROUGH OPENING.

RETURN WALLS- RETURN WALLS AT ENTRANCES MUST BE BUILT-IN BY OTHERS AFTER ENTRANCE ASSEMBLIES ARE IN PLACE. ENTRANCE ASSEMBLY MUST BE SECURELY FASTENED TO WALLS.

ALL INFORMATION IS SUBJECT TO CHANGE.
PLEASE REFERENCE OUR ON-LINE DRAWINGS AT
www.savaria.com FOR THE MOST RECENT UPDATES

MULTILIFT
VERTICAL
PLATFORM LIFTS

THE INFORMATION DISCLOSED HEREIN IS THE EXCLUSIVE PROPERTY OF
 savaria
AND MAY NOT BE USED BY OTHERS WITHOUT PRIOR WRITTEN CONSENT
SHEET# 1/1

Provisions by others - Savaria Link option

If you have the Savaria Link Ethernet remote monitoring option, ensure that you have an Ethernet connection with Internet capability in the vicinity of the unit's controller.

If you have the Savaria Link Wireless remote monitoring option, ensure that you have a wireless signal with Internet capability in the vicinity of the unit's controller.

Multilift PUBLIC Vertical Platform Lift PLANNING GUIDE

Part No. 000790
Copyright © 2020

Savaria Concord Lifts, Inc.
www.savaria.com

Sales
2 Walker Drive
Brampton, Ontario L6T 5E1
Canada
Tel: (905) 791-5555
Fax: (905) 791-2222
Toll Free: 1-800-661-5112

